

CC10.3

Interface Conditions

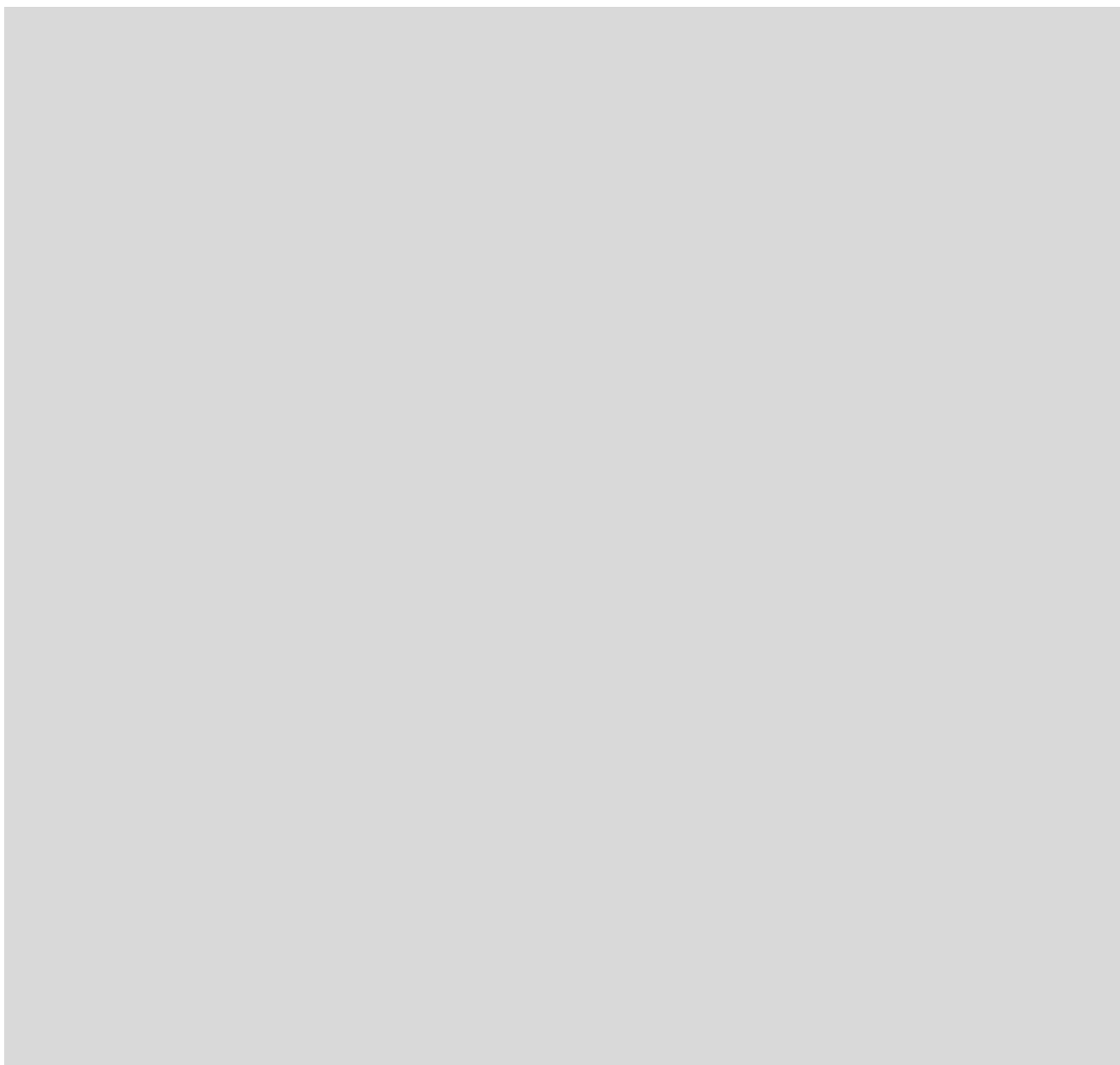

Version

101



CC10.3

Interface Conditions

1070 072 152-101 (95.09) GB



Reg. Nr. 16149-03

© 1995

by Robert Bosch GmbH,
All rights reserved, including applications for protective rights.
Reproduction or handing over to third parties are subject to our written permission.

Discretionary charge 20.– DM

Safety instructions and reading help

Read this instruction manual before you use the CC10.3. Keep this manual in a place where it is always accessible to all users.

Standard operation

This instruction manual contains all of the information required for standard operation of the described products.

The products described were developed, manufactured, tested and documented in accordance with the relevant safety standards. There should be no risk of danger to personnel or property if the specifications and safety instructions relating to the project phase and installation and correct operation of the product are followed.

Qualified personnel

This instruction manual is designed for specially trained PLC personnel. The relevant requirements are based on the job specifications as described by the ZVEI, see:

Anforderungsprofile für NC – Fachkräfte

I + K SPEKTRUM 19

Hrsg.: ZVEI

Stresemannallee 19

60596 Frankfurt

Federal Republic of Germany

ISSN 0932–5018

This instruction manual is designed for NC commissioners. These commissioners require special knowledge of NC controllers.

Interventions in the hardware and software of our products which are not described in this instruction manual may only be performed by our skilled personnel.

Unqualified interventions in the hardware or software or non-compliance with the warnings listed in this instruction manual or indicated on the product may result in serious personal injury or damage to property.

Qualified personnel are persons who

- as **planning personnel**, are familiar with the safety guidelines used in electrical engineering and automation technology.
- as **operating personnel**, are familiar with the equipment used in the field of automation technology and are thus familiar with the operating instructions in this manual.
- as **commissioning personnel**, are authorized to commission, ground and classify electric circuits and devices/systems in accordance with the relevant safety standards.

Safety instructions on the control components

The following warnings and notices may be indicated on the control components themselves and have the following meaning:



Danger: High voltage!



Danger: Battery acid!



Electrostatically – sensitive components!



Disconnect at mains before opening!



Pin for connecting PE conductor only!



For screened conductor only!

Safety instructions in this manual



These symbols are used throughout this manual subject to the following conditions.



DANGER

This symbol is used to warn of the presence of **dangerous electrical current**. Insufficient or lacking compliance with these instructions can result in **personal injury**.

Safety instructions accompanied by this symbol are serially numbered, for example 0.1. The appendix provides translations of the safety notes shown here in all the official EC languages.



DANGER

This symbol is used wherever an insufficient or lacking compliance with instructions can result in **personal injury**.

Safety instructions accompanied by this symbol are serially numbered, for example 0.1. The appendix provides translations of the safety notes shown here in all the official EC languages.



CAUTION

This symbol is used wherever an insufficient or lacking compliance with instructions can result in **damage to equipment or files**.

Safety instructions accompanied by this symbol are serially numbered, for example 0.1. The appendix provides translations of the safety notes shown here in all the official EC languages.



This symbol is used to inform the user of special features.

Safety instructions



DANGER

0.1

Danger to persons and equipment!

Test every new program before operating the system!



CAUTION

0.2

Danger to the module!

Do not insert or remove the module when the control is switched on! This can destroy the module. Switch off or remove the power supply module of the control, external power supply and signal voltage before inserting or removing the module!



CAUTION

0.3

Danger to the module!

All ESD protection measures must be observed when using the module! Avoid electrostatic discharges!

Observe the following protective measures for electrostatically endangered modules (EEM)!

- The employees responsible for the storage, transport and handling must be trained in ESD protection.
- EEMs must be stored and transported in the protective packaging specified.
- EEMs may basically only be handled at special ESD work places set up specifically for this purpose.
- Employees, work surfaces and all devices and tools, which could come into contact with EEMs must be same potential (e.g. earthed).
- Wear an approved earthing strap around your wrist. The grounding bracelet must be connected via a cable with integrated 1 MΩ resistance with the work surface.
- EEMs may on no account come into contact with chargeable objects, these include most plastics.
- When inserting EEMs into devices and removing them, the power source of the device must be switched off.

1.	GENERAL	1-1
1.1	Summary of connections	1-2

2. CONTROL VERSIONS/INSTALLATION NOTES

2.1	Control versions	2-1
2.1.1	Control versions for driving 1 axis, incremental measuring system	2-1
2.1.2	Control versions for driving 1-3 axes, incremental measuring system	2-2
2.1.3	Control versions for driving 1-3 axes, absolute measuring system	2-3
2.2.1	Installation notes CL 400 (14 slots)	2-4
2.2.1.1	Rack installation for basic unit (with CC 10)	2-4
2.2.1.2	Rack installation for expansion unit (with CC 10)	2-5
2.2.2	Installation notes CL 400 (8 slots, refer to Section 2.2.1 for notes)	2-5
2.2.2.1	Rack installation for basic unit (with CC 10)	2-5
2.2.3	Installation notes CL 500 (14 slots, refer to Section 2.2.1 for notes)	2-6
2.2.3.1	Rack installation for basic unit (with CC 10) in conjunction with a ZS 500. The number of CC 10 which can be used is reduced if several ZS 500 are installed.	2-6
2.2.3.2	Rack installation for expansion unit (with CC 10)	2-6
2.2.4	Commissioning instructions for CC 10 modules in conjunction with the PLC CL 500	2-7
2.3.1	Weights	2-8
2.3.2	Temperatures	2-8
2.2.3	Humidity (Relative)	2-8
2.3.4	Vibrations and shock	2-8
2.3.5	Protection class	2-8
2.3.6	Dust protection	2-8
2.3.7	Electromagnetic Influences	2-9
2.3.8	Interference Immunity	2-9
2.3.9	Position, Location	2-9
2.3.10	Operating altitude	2-9
2.3.11	Constraints	2-9

3. OPERATING AND PROGRAMMING PANEL BPF 10/BPF 10 E

3.1	Hand-held BPF 10	3-1
3.1.1	Mechanical design	3-1
3.1.3	Display	3-2
3.1.4	Emergency-off	3-2
3.1.5	Consent key	3-2
3.1.6	Cables and connectors	3-3
3.1.7	Interface	3-3
3.1.8	Adapter cable	3-4
3.1.9	Extension cable	3-5
3.1.10	Ambient conditions	3-5
3.2.1	Mechanical design	3-6
3.2.3	Display	3-7
3.2.4	Cables and connectors	3-7
3.2.6	Ambient conditions	3-8

4. ELECTRICAL CONNECTIONS

4.1	General	4-1
4.2	Power supply	4-1
4.2.1	Power connection	4-2
4.2.2	Input	4-3
4.2.3	Output	4-4
4.3	PE Conductors and Screens	4-5
4.4	Interference suppression	4-6
4.4.1	General	4-6
4.4.2	Examples	4-7
4.4.2.1	Contact circuit	4-7
4.4.2.2	Connecting an inductive load	4-8
4.4.2.3	Mains connection	4-8
4.5	Ready contact	4-9

5. CONTROL LOOP INTERFACE

5.1	Overview	5-1
5.1.1	Control variant for incremental measuring systems	5-1
5.1.2	Control variant for absolute measuring systems	5-2
5.2	Setpoint output	5-3
5.2.1	General	5-3
5.2.2	Technical data	5-3
5.2.3	Connecting servo-amplifiers	5-4
5.2.3.1	Connecting servo-amplifiers with differential input	5-4
5.2.3.2	Connecting servo-amplifiers with differential input and GND in drive amplifier permanently connected with housing (e.g. Servodyn-TC)	5-5
5.2.3.3	Connecting servo-amplifiers with GND input	5-6
5.2.3.4	Special features	5-6
5.3	Measuring systems	5-7
5.3.1	General	5-7
5.3.2	Technical data	5-7
	Incremental measuring system	5-7
	General	5-7
5.3.3	Direct connection of measuring systems from Messrs. Heidenhain	5-9
	Cable from Servo to Measuring System (ROD)	5-9
5.3.4	Direct connection of measuring systems from Messrs. Stegmann	5-11
5.3.5	Connecting measuring systems from Messrs. Heidenhain with EXE unit	5-12
5.3.6	Shorting plug for measuring system input (applies only to incremental measuring system)	5-13
5.3.7	Permissible digital measuring systems	5-13
5.3.8	Recommended pulse-shaper electronics (EXE) and encoder	5-14
5.3.9	Revolution-coded incremental encoder to TE60	5-15
5.3.9.1	General function description of the encoder	5-15
5.3.9.2	Limits set by the encoder	5-15
5.3.9.3	Start-up cycle	5-15
5.3.10	Monitors	5-16
5.4	Absolute measuring systems	5-17
5.4.1	General	5-17
5.4.2	Technical data	5-18

5.4.3	Connection of the measuring system	5–20
5.4.4	Functional description of the interface	5–21
5.4.4.1	Data transfer for single–turn encoders (refer to Fig. 5.4.2)	5–21
5.4.4.2	Data transfer for multi–turn encoders	5–24
5.4.5	Monitors	5–25

6. DATA INTERFACES

6.1	Overview	6-1
6.2	Serial interface V.24/20 mA	6-2
6.2.1	General description	6-2
6.2.2	V.24 interface	6-2
6.2.3	20 mA interface	6-3
6.3	Interface for the operating and programming panel BPF 10/BPF 10 E	6-5

7.	DIGITAL INTERFACE	7-1
7.1	CC 10 Interface structure	7-2
7.2	Communication of CC10 with the CC10LOAD module	7-3
7.2.1	Parameters of the CC10LOAD module:	7-3
7.2.2	Exchanging interface signals with PLC	7-4
7.3	Digital interface basis	7-6
7.3.1	Inputs basis interface	7-6
7.3.2	Outputs basis interface	7-7
7.4	Digital Interface Extension	7-8
7.4.1	Overview CC10 inputs (PLC---> CC10)	7-8
7.4.2	Overview CC10 outputs (CC10---> PLC)	7-9
7.5	Signal descriptions	7-10
7.5.1	General	7-10
7.5.2	Notes on the signal description	7-10
	RESTART	I 0.5 7-12
	ACKNOWLEDGE MULTIPLE OUTPUT	I 0.6
	MULTIPLE OUTPUT STROBE	O 0.7 7-13
	MULTIPLE INPUT STROBE	I 0.7
	ACKNOWLEDGE MULTIPLE INPUT	O 0.6 7-14
	OPERATING MODES	I 1.0 – I 1.2 7-15
	DATA ENABLE	I 1.3 7-18
	START	I 1.4 7-19
	EDIT DISABLE	I 1.5 7-20
	SET ACTUAL VALUE	I 1.6 7-21
	BASIC SETTING	I 1.7 7-23
	DRIVE ON AXIS 1	I 2.0
	DRIVE ON AXIS 2	I 2.3
	DRIVE ON AXIS 3	I 2.6 7-24
	FEED ENABLE AXIS 1	I 2.1
	FEED ENABLE AXIS 2	I 2.4
	FEED ENABLE AXIS 3	I 2.7 7-27
	REFERENCE POINT SWITCH AXIS 1	I 2.2
	REFERENCE POINT SWITCH AXIS 2	I 2.5
	REFERENCE POINT SWITCH AXIS 3	I 3.0 7-28
	USER INPUT 1	I 3.1
	USER INPUT 2	I 3.2
	USER INPUT 3	I 3.3
	USER INPUT 4	I 3.4 7-29

AUTO RESTART	I 3.5	7–29
OPTIONAL STOP	I 3.6	7–30
MAN +	I 4.0	
MAN –	I 4.1	
AXIS 1	I 4.2	
AXIS 2	I 4.3	
AXIS 3	I 4.4	7–31
FEED %	I 4.5, 4.6, 4.7	7–32
PRESET OPERATING MODE PLC/BPF	I 5.0	7–33
CONDITIONAL JUMP	I 5.1	7–33
MULTIPLE INPUT ADDRESS	I 5.4 – I 5.7	
MULTIPLE INPUT DATA	I 6.0 – I 7.7	7–34
EXTERNAL PROGRAM SELECTION	I 5.4 – I 5.7	7–35
EXTERNAL BLOCK SELECTION	I 5.4 – I 5.7	7–36
INTERFACE MODE	I 5.4 – I 5.7	7–37
ACKNOWLEDGE MULTIPLE INPUT	O 0.6	7–38
MULTIPLE OUTPUT STROBE	O 0.7	7–38
OPERATING MODES	O 1.0 – O 1.2	7–38
PROGRAM ACTIVE	O 1.3	7–39
IN POSITION AXIS 1	O 1.4	
IN POSITION AXIS 2	O 1.5	
IN POSITION AXIS 3	O 1.6	7–40
BASIC SETTING	O 1.7	7–40
REFERENCE POINT APPROACH AXIS 1	O 2.0	
REFERENCE POINT APPROACH AXIS 2	O 2.1	
REFERENCE POINT APPROACH AXIS 3	O 2.2	7–41
SOFTWARE LIMIT SWITCH ACTIVE	O 2.3	7–42
USER OUTPUT 1	O 2.4	
USER OUTPUT 2	O 2.5	
USER OUTPUT 3	O 2.6	
USER OUTPUT 4	O 2.7	7–43
ACTUAL VALUE SET AXIS 1	O 3.0	
ACTUAL VALUE SET AXIS 2	O 3.1	
ACTUAL VALUE SET AXIS 3	O 3.2	7–43
MULTIPLE OUTPUT ADDRESS	O 3.4 – 3.7	
MULTIPLE OUTPUT DATA	O 4.0 – 5.7	7–44
PROGRAM SELECTED	O 6.1	7–45
NC READY	O 6.5	7–45
ON–LINE PLC	O 6.6	7–46

BPF CONNECTED	O 6.7	7-46
GENERAL ERROR	O 7.0	
ERROR CODE	O 7.1 – O 7.7	7-47
PRESET SETPOINT, 1ST AXIS	I 8.0 – I 11.7	7-48
1ST PRESET SETPOINT INACTIVE, 1ST AXIS	I 11.2	7-49
FEED %	I 11.3 – I 11.6	7-50
PRESET SETPOINT, 2ND AXIS	I 12.0 – 15.7	7-51
PRESET SETPOINT INACTIVE, 2ND AXIS	I 15.2	7-51
PRESET SETPOINT, 3RD AXIS	I 16.0 – 19.7	7-51
PRESET SETPOINT INACTIVE, 3RD AXIS	I 19.2	7-51
PRESET SETPOINT POSITION	I 20.0	7-51
G90/G91	I 20.1	7-51
SETPOINT DISPLAY	I 20.2	7-51
ACTUAL VALUE DISPLAY	I 20.3	7-52
ACKNOWLEDGE DATA CHANNEL OUTPUT	I 20.6	7-52
REQUIRED DATA INPUT STROBE	I 20.7	
ACKNOWLEDGEMENT FOR REQUIRED DATA INPUT	O 20.6	7-53
DISPLAY 1ST AXIS	O 8.0 – 11.7	7-54
DISPLAY 2ND AXIS	O 12.0 – 15.7	7-54
DISPLAY 3RD AXIS	O 16.0 – 19.7	7-54
ACKNOWLEDGEMENT FOR REQUIRED DATA INPUT	O 20.6	7-54
DATA CHANNEL OUTPUT STROBE	O 20.7	
ACKNOWLEDGE DATA CHANNEL OUTPUT	I 20.6	7-55

8. Error codes 1

Safety Instructions

A.1.1	Dansk	A-1
A.1.2	Deutsch	A-4
A.1.3	Ελληνικά	A-7
A.1.4	Español	A-10
A.1.5	Français	A-13
A.1.6	Italiano	A-16
A.1.7	Nederlands	A-19
A.1.8	Português	A-22
A.1.9	Suomi	A-25
A.1.10	Svenska	A-28

1. GENERAL

This description refers to the CC 10 operating system software as from version C40.

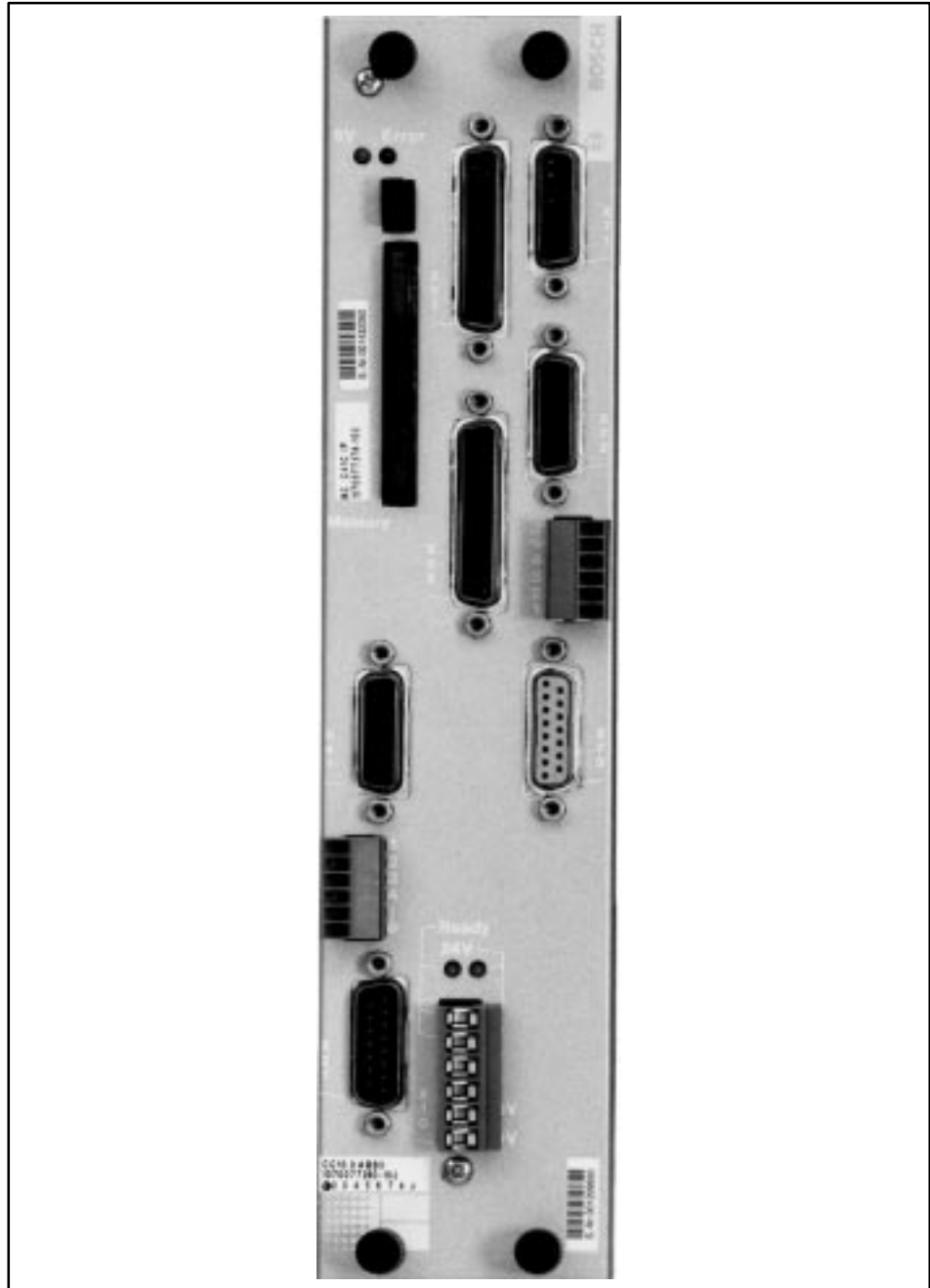

The control system overview describes the applications, control modules and their components and the main connections of importance to the customer.

This manual contains information for planning and commissioning the CC 10 control system

1.1 Summary of connections

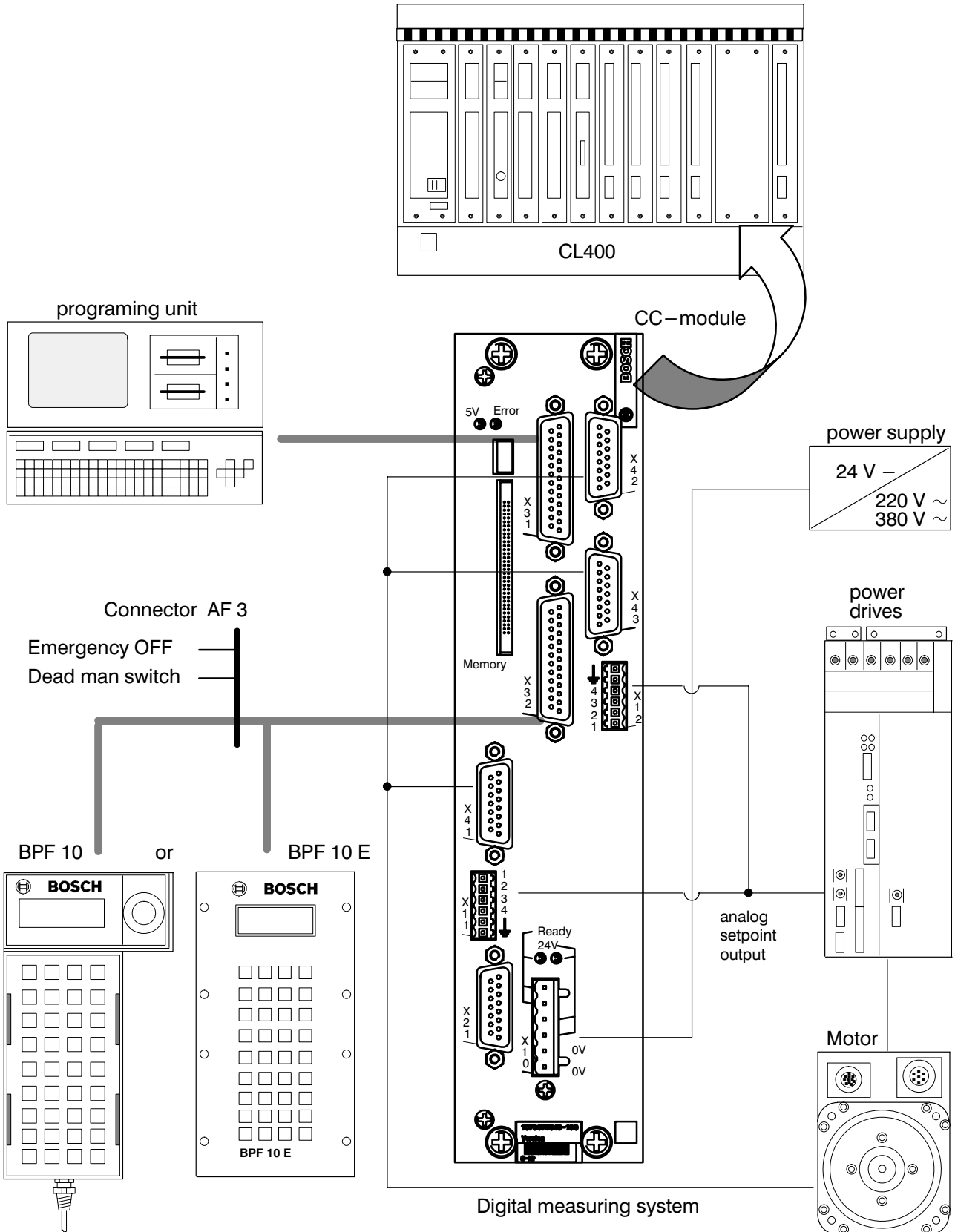

2. CONTROL VERSIONS/INSTALLATION NOTES

2.1 Control versions

2.1.1 Control versions for driving 1 axis, incremental measuring system

Incremental measuring system input or revolution-coded, incremental measuring system input, analog setpoint output, V.24/20 mA interface.

Designation: CC10.3 INC1 – V.24/20 mA (refer to Fig. 2.1.1)

Order number: 075702

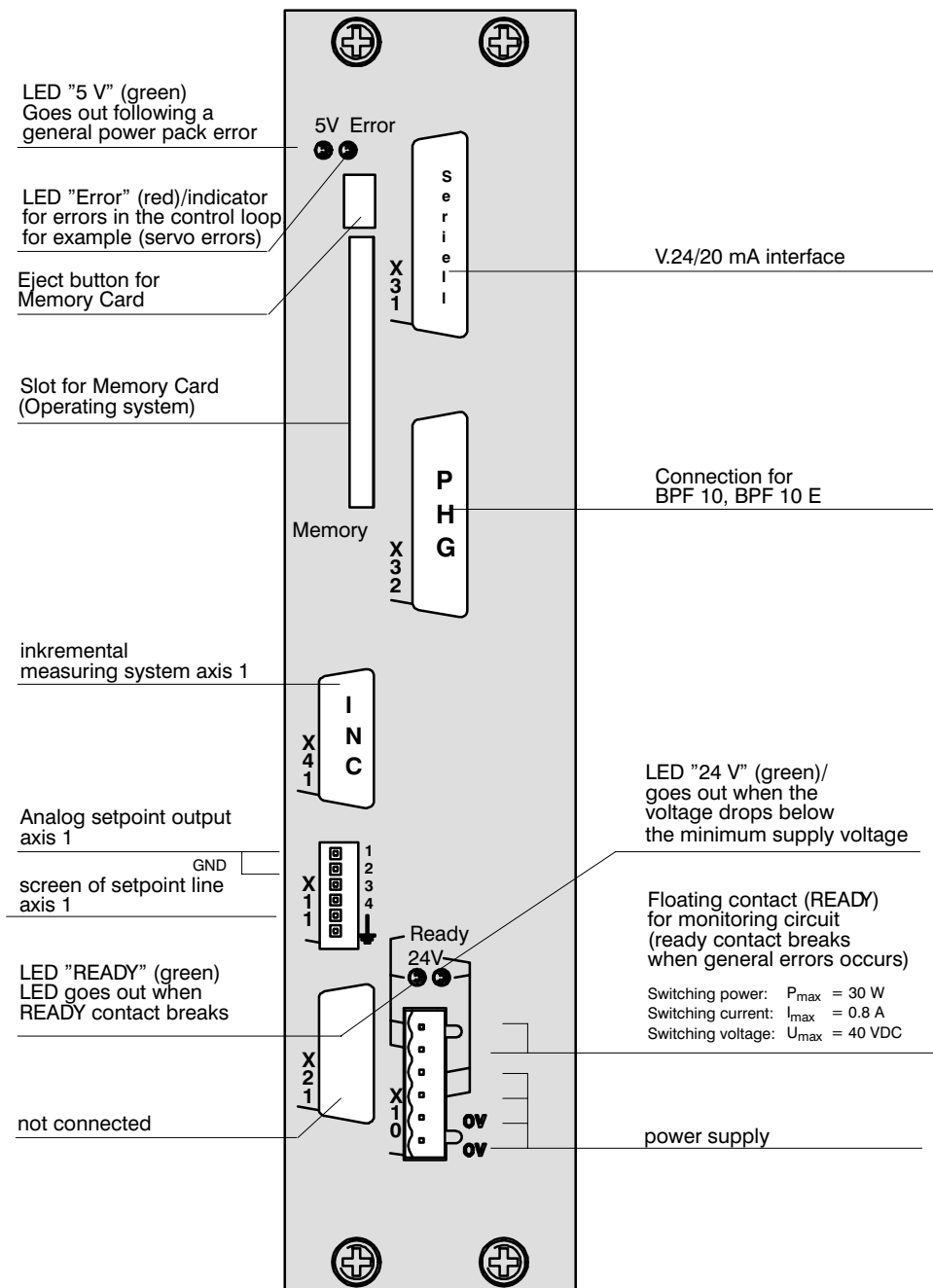

Fig. 2.1.1

2.1.2 Control versions for driving 1–3 axes, incremental measuring system

Incremental measuring system input or revolution-coded, incremental measuring system input, analog setpoint output, V.24/20 mA interface.

Designation: CC10.3 INC3 – V.24/20 mA (refer to Fig. 2.1.2)

Order number: 075642

Those function elements not described here are identical with those described in Section 2.1.1

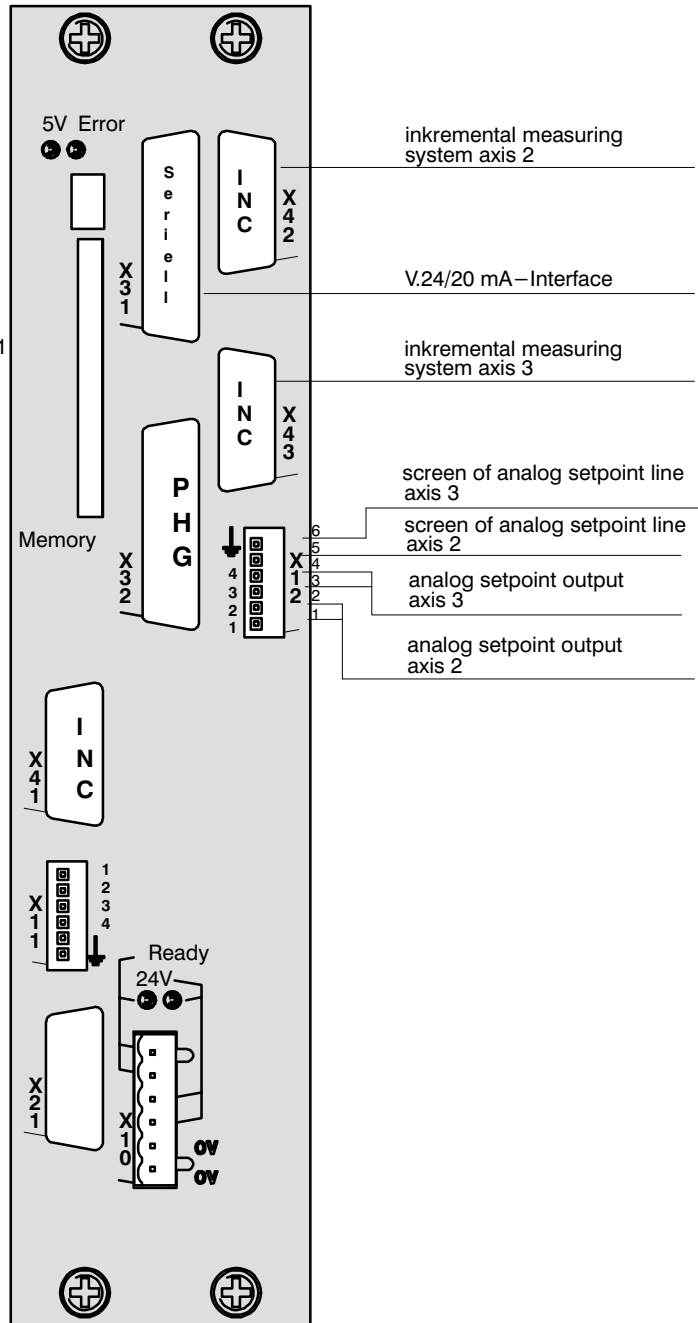

Fig. 2.1.2

2.1.3 Control versions for driving 1–3 axes, absolute measuring system

Optionally incremental or absolute measuring system input for the 1st axis, absolute measuring system input for the 2nd and 3rd axes, analog setpoint output, V.24/20 mA interface

Designation: CC10.3 ABS3 – V.24/20 mA (refer to Fig. 2.1.3)

Order number: 075703

Those function elements not described here are identical with those described in Section 2.1.1

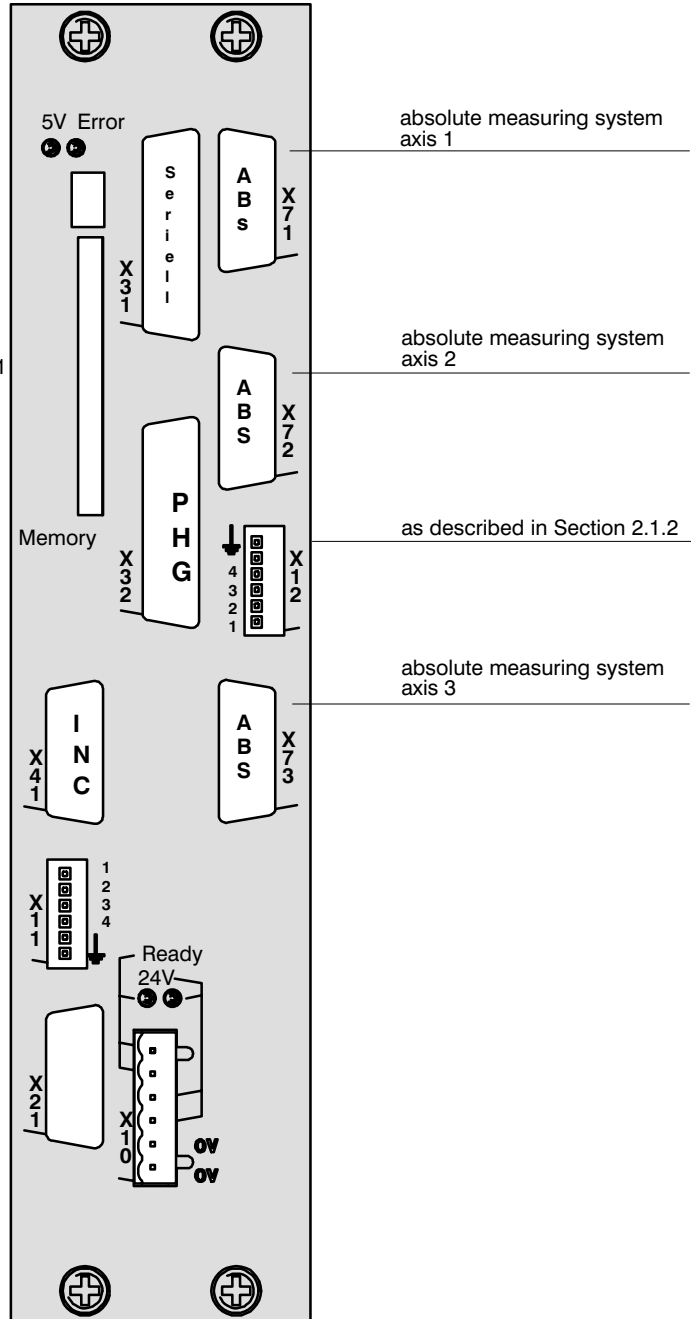

Fig. 2.1.3

2.2 Installation notes

2.2.1 Installation notes CL 400 (14 slots)

Notes

- Unused slots must be covered by dummy panels in order not to impair the air circulation.
- One blower must be installed in the rack.
- The CC 10 units must be installed above the blowers.
- If a number of racks are arranged one above the other, care must be taken to ensure that the temperature of the air supply to the uppermost rack does not exceed 55 degrees Celsius (otherwise lower ambient temperature for the CC 10).
The rack arrangement is illustrated in the equipment manually.
The CC 10 cannot be installed in a decentralized expansion unit.

2.2.1.1 Rack installation for basic unit (with CC 10)

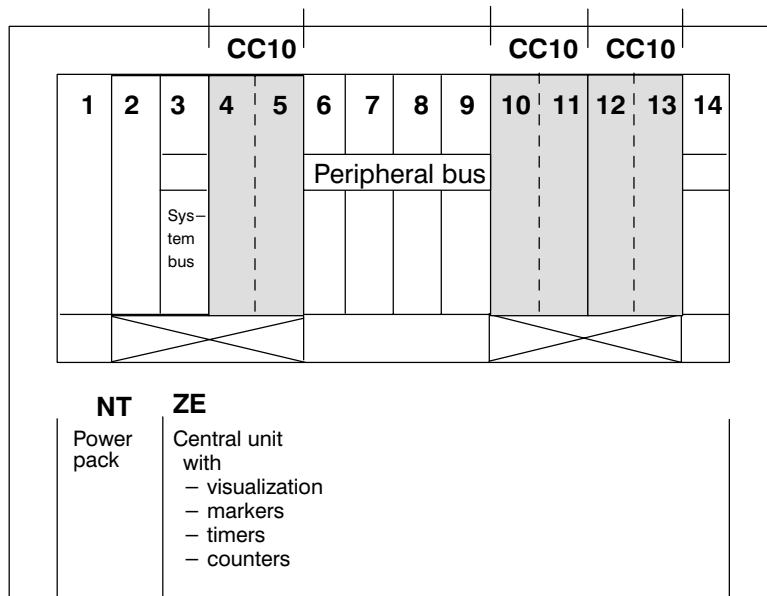

Fig. 2.2.1

2.2.1.2 Rack installation for expansion unit (with CC 10)

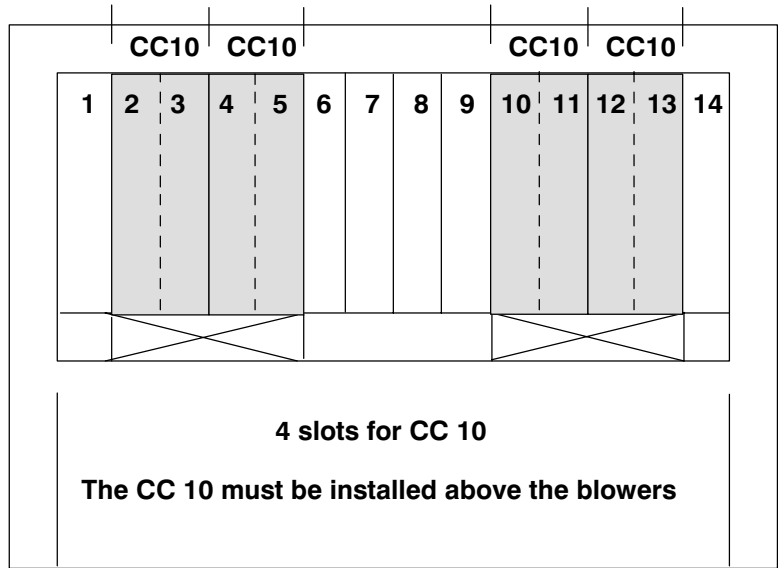

Fig. 2.2.2

2.2.2 Installation notes CL 400 (8 slots, refer to Section 2.2.1 for notes)

2.2.2.1 Rack installation for basic unit (with CC 10)

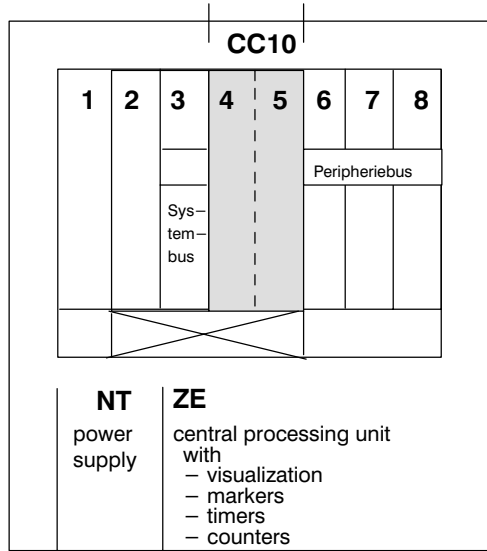

Fig. 2.2.3

2.2.3 Installation notes CL 500 (14 slots, refer to Section 2.2.1 for notes)

2.2.3.1 Rack installation for basic unit (with CC 10) in conjunction with a ZS 500.
The number of CC 10 which can be used is reduced if several ZS 500 are installed.

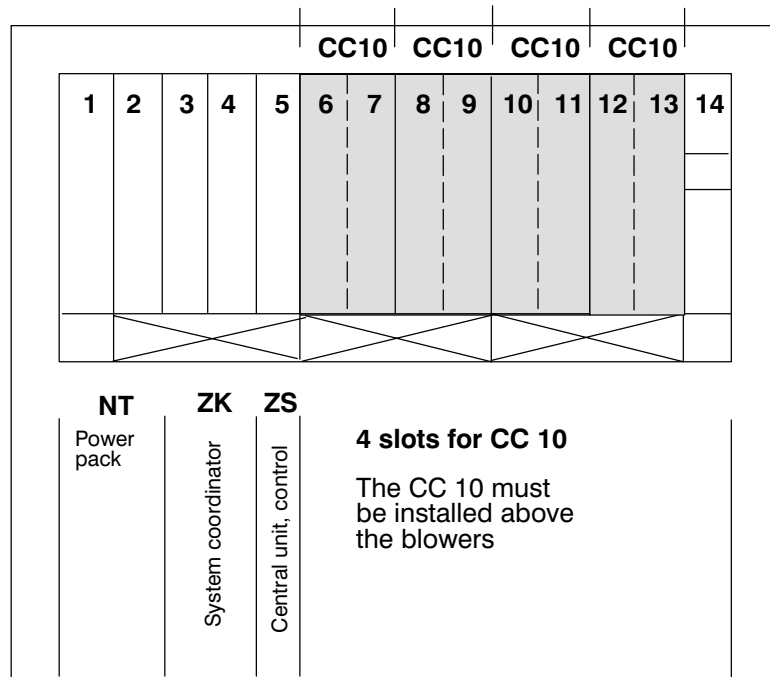

Fig. 2.2.4

2.2.3.2 Rack installation for expansion unit (with CC 10)

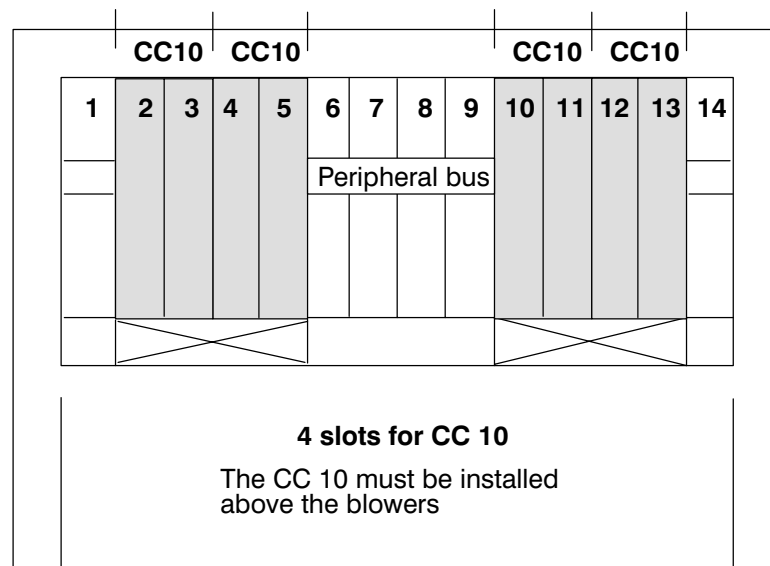

Fig. 2.2.5

2.2.4 Commissioning instructions for CC 10 modules in conjunction with the PLC CL 500

(These instructions can also be transferred to the PLCs CL 300, CL 400, with the exception of the address area).

- The interface conditions of the CL 500 apply.
- The number of CC 10 modules which can be installed is restricted by the total permitted current consumption, size of the interface area and number of possible slots.
- A CC10 interface occupies 4 bytes outside the extended field. A ZS 500 can address 64 bytes in the extended field. Consequently, up to 16 CC10 modules can theoretically be addressed per ZS 500.
- Addressing of the CC 10 modules must be such that the address area of a ZS 500 (64 bytes) is not exceeded.
- The CC 10 modules must be installed only in the slots above the blowers owing to the heat generated by them. The same guidelines as for the CL 300 apply here.
- The addresses of the CC10 modules are defined at the corresponding module DIP switch.
- The CC10 is supplied with the preset address 0.
- When performing commissioning, it must be ensured that there is no multiple assignment of the start addresses, otherwise driver components on the modules may be destroyed.
- CC10 modules are used exclusively in the extended field. The rules for handling the extended interface of the CL 300 are generally applicable here. The CC10 replace the PLC interface data when the **CC10LOAD** module is called up in the PLC program.
- If several modules are installed in the auxiliary field, it is recommended to separate data exchange with the individual modules in time. This reduces the load on the CL 500 bus. A large number of auxiliary I/O field access operations in succession can place a considerable load on CL 500 timing, since the system bus is blocked for the other processor modules during this time. This does not just apply specifically to the CC 10, but to all modules in the auxiliary field. As regards the CC 10 in particular, it should be ensured that only the actually required interface areas are written/read.

Example for optimised bus timing:

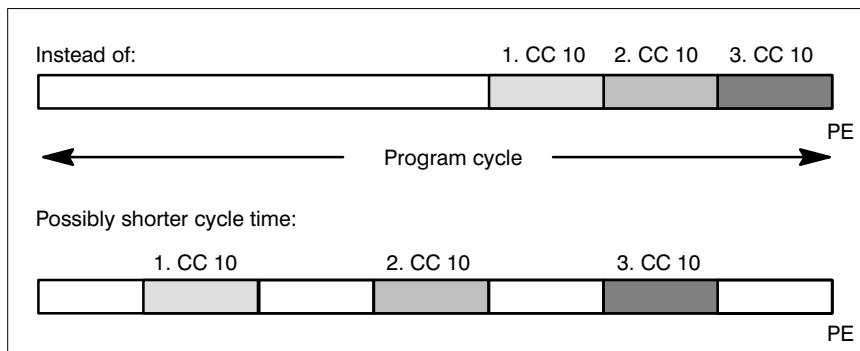

2.3 Ambient conditions

2.3.1 Weights

CC 10.3:	3.1 kg (max. configuration)
BPF 10 E:	1.7 kg
BPF 10:	1.9 kg

2.3.2 Temperatures

Ambient temperature:	+5 to 55 degrees C
Rate of temperature change:	3 degree C/min
Storage temperatures:	-25 to +75 degrees C



CAUTION

2.1

The average temperature of the surrounding air must not exceed 50 °C within a 24 hour period!

2.2.3 Humidity

(Relative)

During operation:	10–15 % (up to 40 degrees C)
During storage:	10–90 % for all modules



CAUTION

2.2

The surrounding air must be free of high concentrations of dust, acids, alkalis, corrosives, salts, metallic fumes or other electrically conductive impurities. Dew must not be allowed to form.

2.3.4 Vibrations and shock

Type testing of the module was performed in accordance with IEC 68–2–6/IEC 68–2–27. The modules withstood a vibration test with sinusoidal vibrations with a maximum acceleration of 2 g as well a shock test with a peak acceleration of 15 g in 3 directions. The values do not apply to continuous load.

2.3.5 Protection class

CC 10.3:	IP 20 as per DIN 40050
BPF 10:	IP54
BPF 10 E:	Front panel IP54 Rear panel IP00

2.3.6 Dust protection

Protection class 1 (VDE 110, Part 1)

2.3.7 Electromagnetic Influences



CAUTION

2.3

Strong electromagnetic fields should not be allowed to build up in the immediate proximity of the units.

2.3.8 Interference Immunity

- a) Static discharge acc. to IEC 801–2, severity better than 3
- b) Mains-borne interference of the voltage supply acc. to IEC 801–4, severity better than 3.c) Non-mains-borne interference IEC 801–3
Test field strength in frequency band 27–500 MHz > 10 V/m
- c) Non-mains-borne interference IEC 801–3
Test field strength in frequency band 27–500 MHz > 10 V/m

2.3.9 Position, Location

- Position: vertical, in the card rack
- Location: Mounted in cubicle acc. to IP54 in the card rack

2.3.10 Operating altitude

max. 1000m above sea level

2.3.11 Constraints

Norms, directives, regulations, standards

The control system is designed and manufactured on the basis of the following standards and directives:

- BOSCH Safety Technical Directives
- VDE 0113 (EN 60 204)
- VDE 0160
- IEC 801 (interference definitions)
- IEC 68 (mech. strength)
- Humidity class F acc. to DIN 40 040
- Protection standards acc. to DIN 40 050 (incl. IP 00, IP 20, IP54)
- Transport vibration test acc. to BOSCH norm N42 AP 450
- Connection and operation of the control system acc. to IEC 550 and VDE 551

3. OPERATING AND PROGRAMMING PANEL BPF 10/BPF 10 E

The operating and programming panel is available in two versions:

- as BPF 10/hand-held unit and
- as BPF 10 E/panel-mounted version.

3.1 Hand-held BPF 10

3.1.1 Mechanical design

The hand-held unit BPF 10 is intended for mobile applications. It comprises a housing containing the electronics. The keypad, display unit and EMERGENCY-OFF key are located on the front. It is connected to the control system via a cable. It is made of a thermoplastic material and colored black.

Protection class: IP54

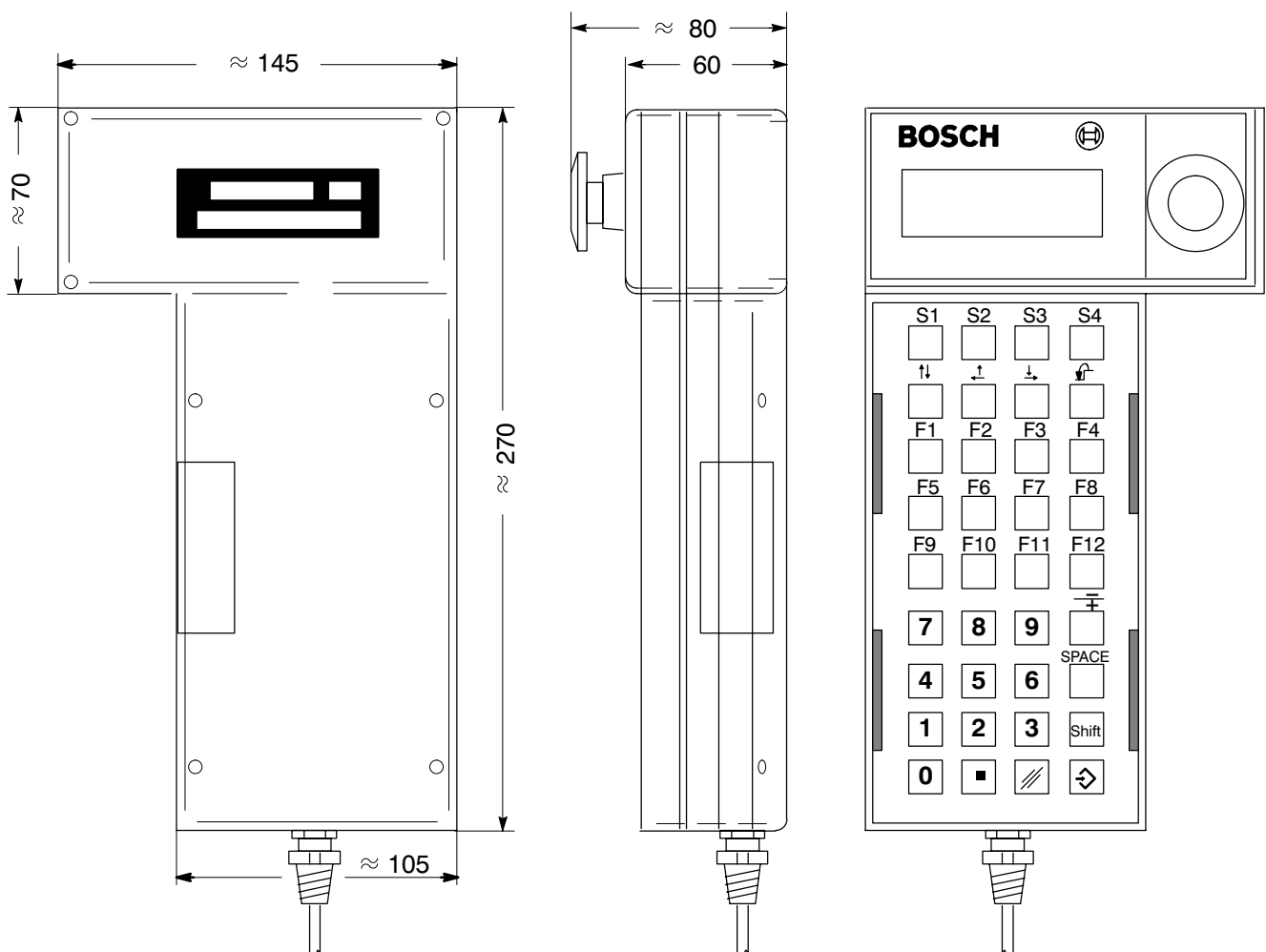



Fig. 3.1.1

3.1.2 Keypad

The BPF has a total of 36 keys.

The top 4 keys are freely definable function keys. The corresponding function is indicated in the display above it.



The level return key  can be used to leave the current function level and jump back to the preceding one.

3.1.3 Display

An LCD display unit (4 x 20 positions) with alphanumeric characters is used as the display.

Character height: approx. 5 mm.

3.1.4 Emergency-off

The EMERGENCY-OFF key is a slam button with interlocked switch and reliably opening contact.

Color: red switch element with yellow contrast surface.

Load: 24 V/2 A – the voltage in the EMERGENCY-OFF circuit must not rise above or fall below 24 V +20 % – 15 %.



CAUTION

3.1

In order to be able to remove the control panel during operation, EMERGENCY OFF in the interface controller must be bypassed, thereby suppressing the machine's EMERGENCY OFF function.

3.1.5 Consent key

The CONSENT KEY is located on the side panel of the BPF 10.

Internal NC evaluation of the CONSENT KEY takes place only on the software side.; there is no hardware evaluation.

It must be pressed when one of the function keys F1–F12 is to be activated. The key is positioned in such a way that it cannot be simply circumvented (for instance by jamming the switching element). The contact in the consent key is opened by spring force.

The consent key should be linked to the safety circuit of the interface controller via an auxiliary relay.

3.1.6 Cables and connectors

Type: LIYCY–CY 4 x 0.3 mm² + 3 x 2 x 0.19 mm²
Order No.: 914506

Cable length: 8 m standard
extendable by the user to max. 30 m.

Pin assignment: Refer to Section 3.1.7

Connector: 25–pole D–SUB connector

Note:

The BPF 10 is only available with already connected cable (8 m) from Bosch.

Access to the EMERGENCY-OFF contact is at the wiring connector to the EMERGENCY-OFF circuit.

3.1.7 Interface

A current-loop interface is used to ensure safe and interference-free data transfer between BPF 10 and the control system. The connection between the BPF 10 and the control unit is permanently monitored by the operating system of the CC10.3. The consent key has two channels and is transmitted as key information to the control system and made available at the X22 plug to the connection field (AF3) as a contact for linking to the interface controller. The connection field (AF3) is required to enable the circuits for EMERGENCY-OFF and consent key to be brought out from the BPF cable.

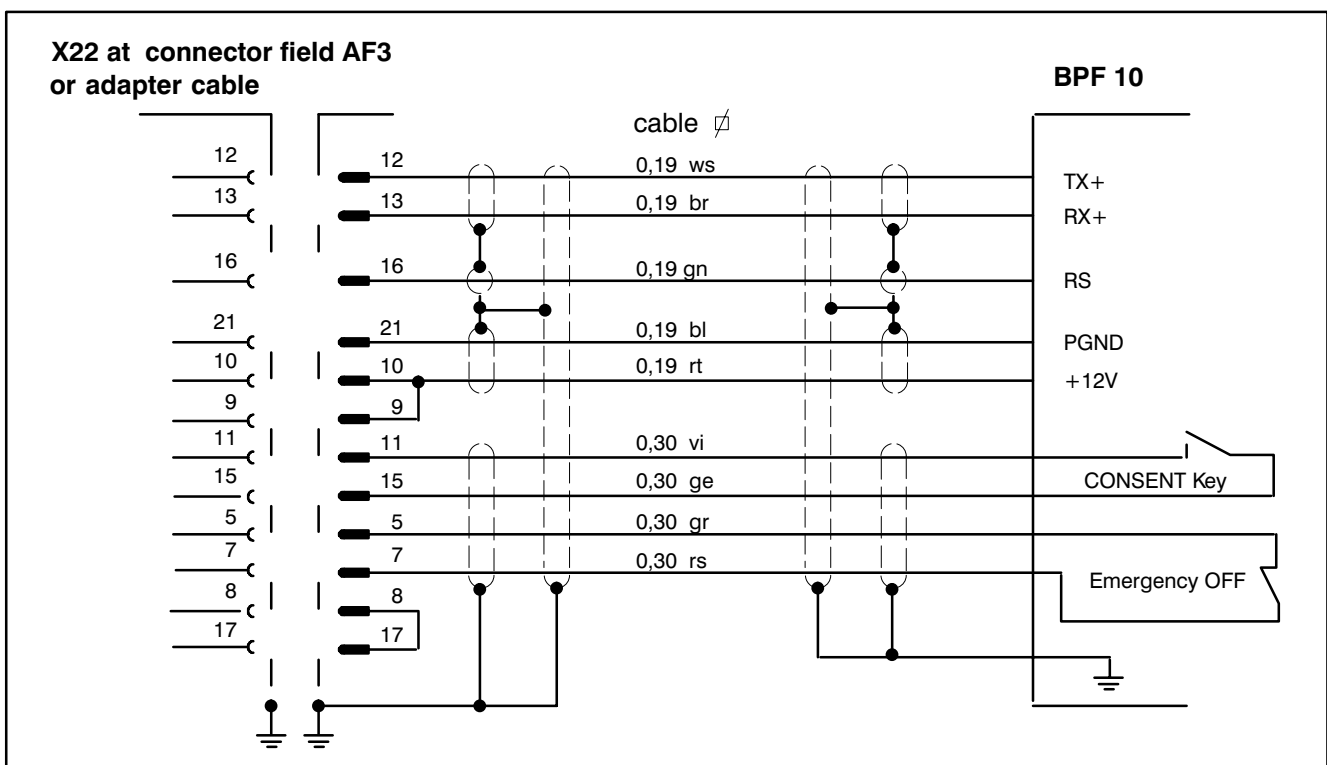

Fig. 3.1.2

3.1.8 Adapter cable

In order that the EMERGENCY-OFF and CONSENT KEY signals can be wired in the switch cabinet, the BPF 10 must not be plugged on directly via the interface of the CC10.3, but should instead be connected with the control system via an adapter cable (see fig. 3.1.3) and a separate connection field.

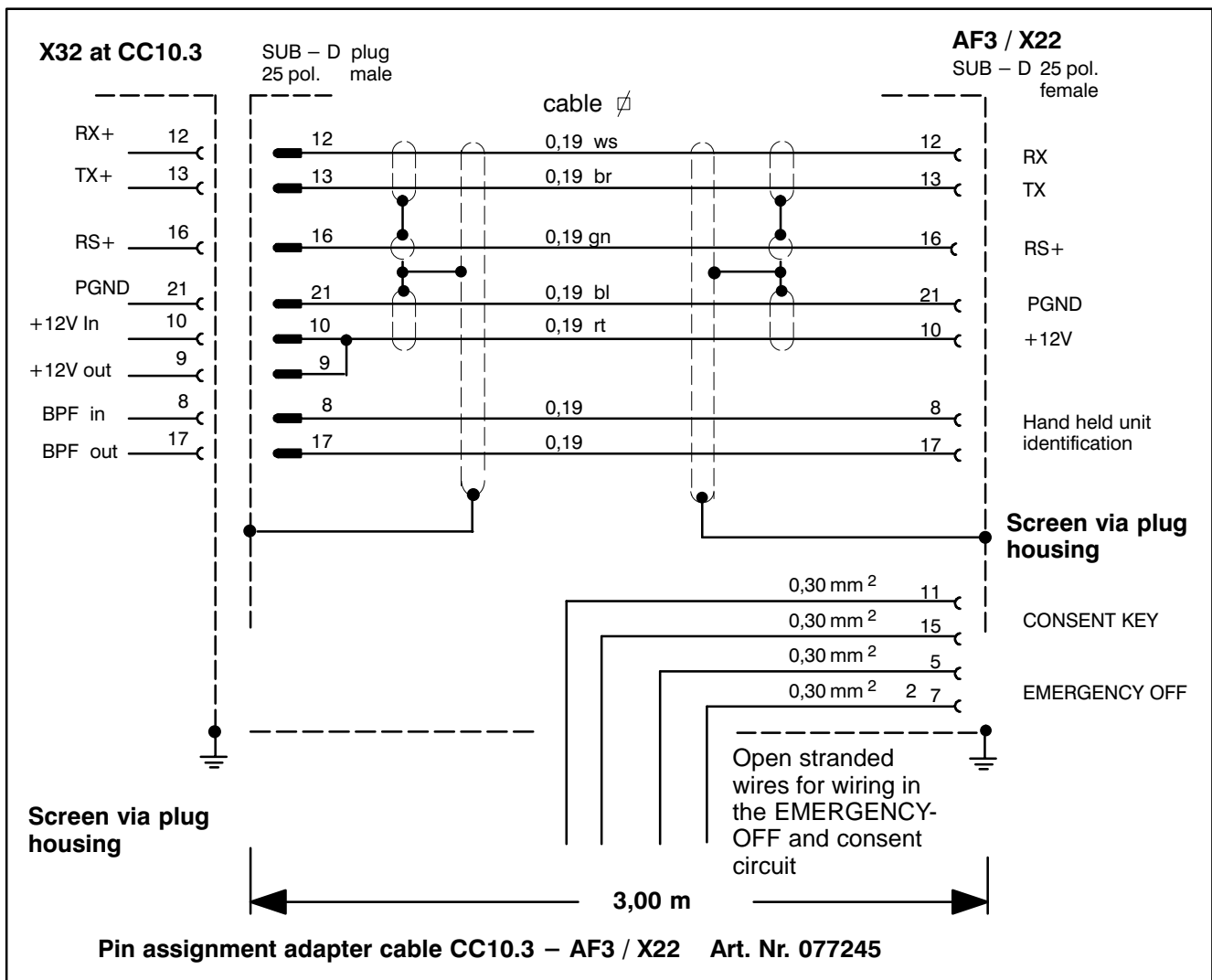

Fig. 3.1.3

3.1.9 Extension cable

The connection between the connection field (AF3) and the BPF 10 can be extended by 45 m with a suitable cable. See fig. 3.1.3.

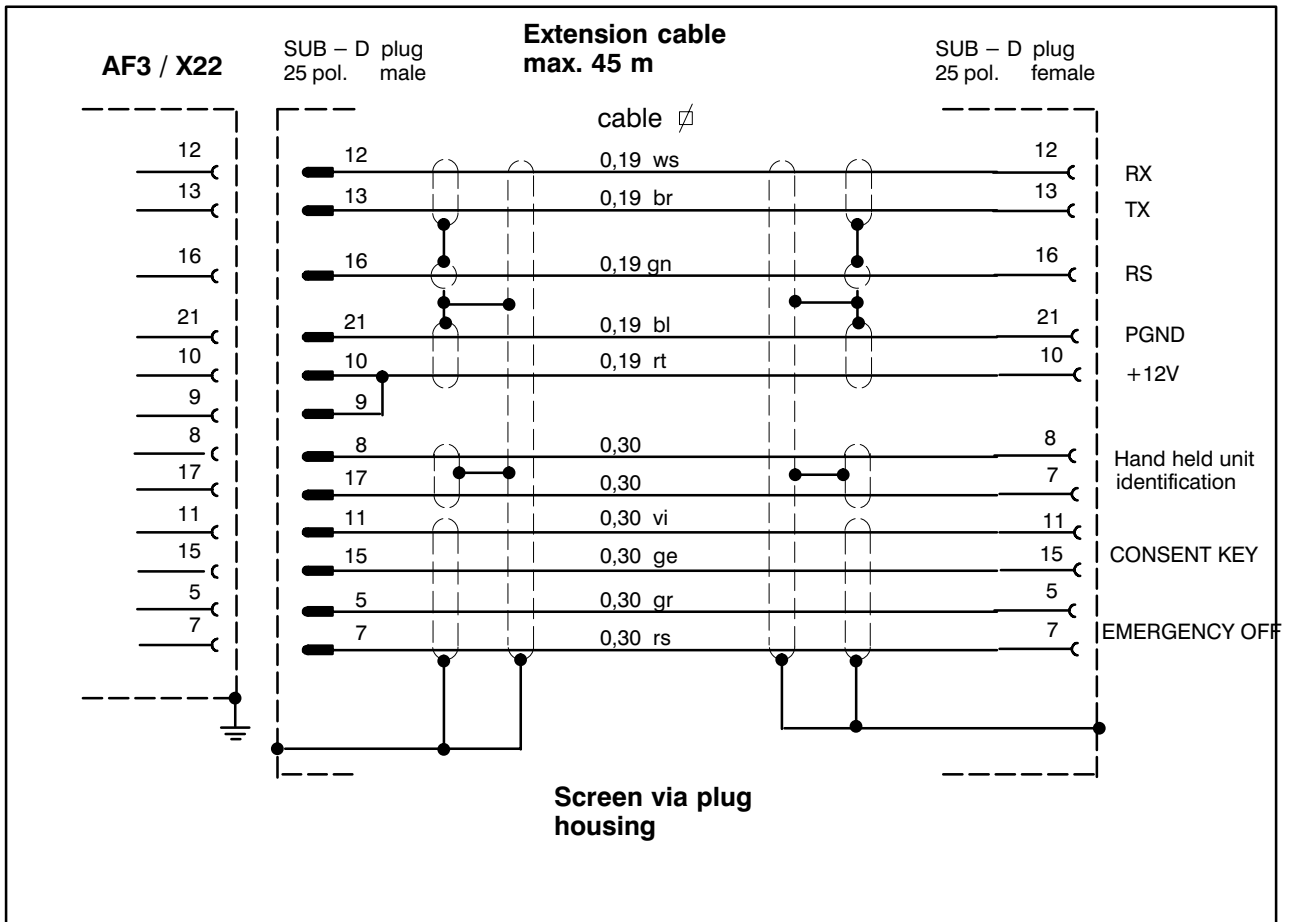

Fig. 3.1.4

3.1.10 Ambient conditions

Operating temperature range: +5 to +45 degrees Celsius
 Storage temperature range: -20 to +65 degrees Celsius

3.2 BPF 10 E panel-mounted version

3.2.1 Mechanical design

The panel-mounted version BPF 10 E is designed for installation in housing cut-outs (e.g. cabinet door, control panel). It consists of a scaled panel to which the electronics of the programming unit BPF 10 is secured. The EMERGENCY-OFF key and the consent key are not required and must be jumpered in the connector of the CC 10.

Protection class

From the front panel: IP54

From the rear: IP00

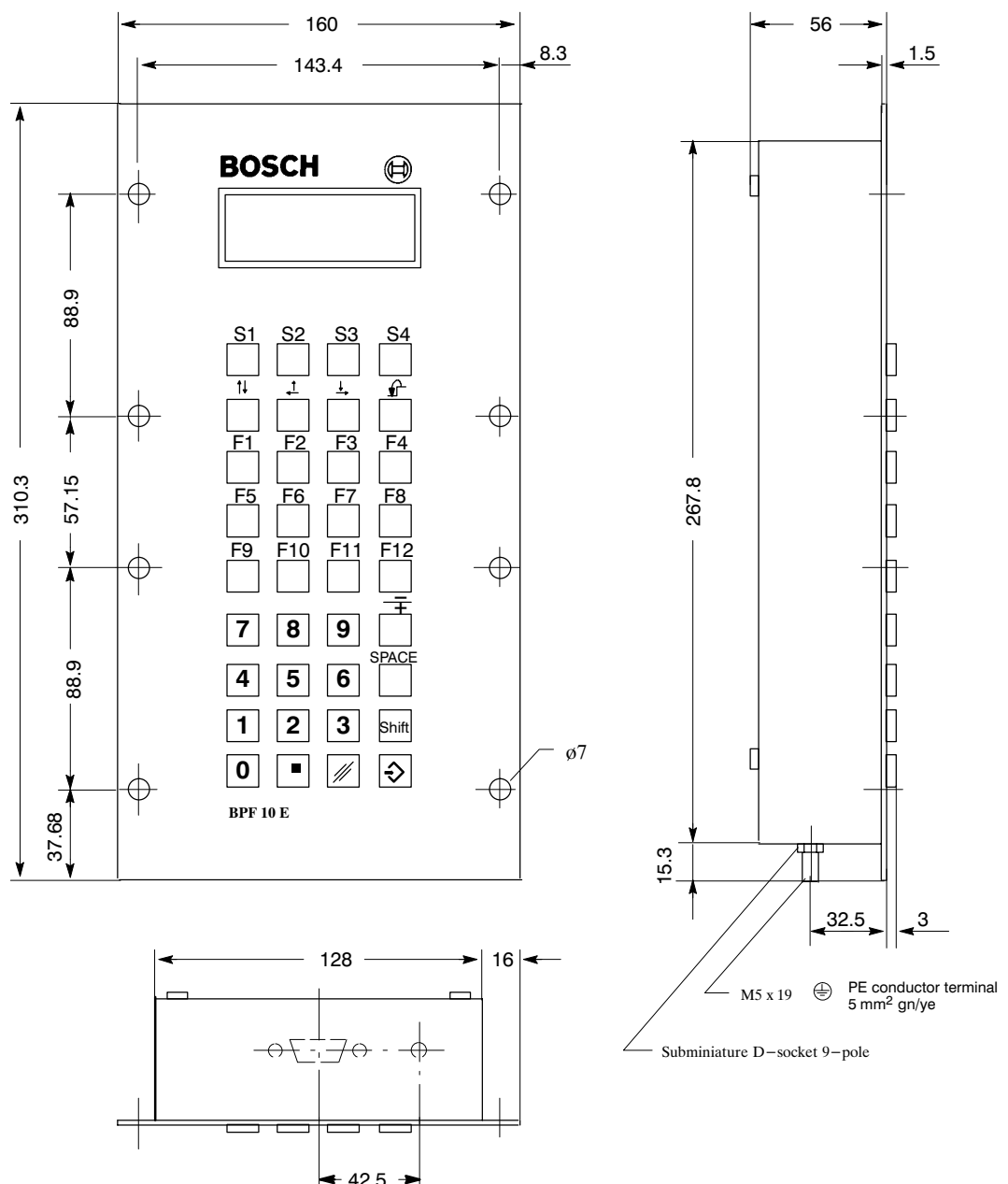

Fig. 3.2.1

3.2.2 Keypad

The panel-mounted version BPF 10 E has the same keypad as the hand-held version BPF 10. Further information on the keypad can be found in Section 7.1.2. The consent and EMERGENCY-OFF keys are not included.

3.2.3 Display

An LCD display unit (4 x 20 positions) with alphanumeric characters is used as the display. All ASCII characters can be displayed.

Character height: approx. 5 mm.

3.2.4 Cables and connectors

Type: e.g. LIYCY 7 x 0.14 mm² /Order No.: 908558

Cable length: max. 30 m

Connector: 9-pole D-Sub

Cables available from Bosch (accessories)

Cable 2.5 m: Order No. 056574

Cable 10 m: Order No. 056808

3.2.5 Interface

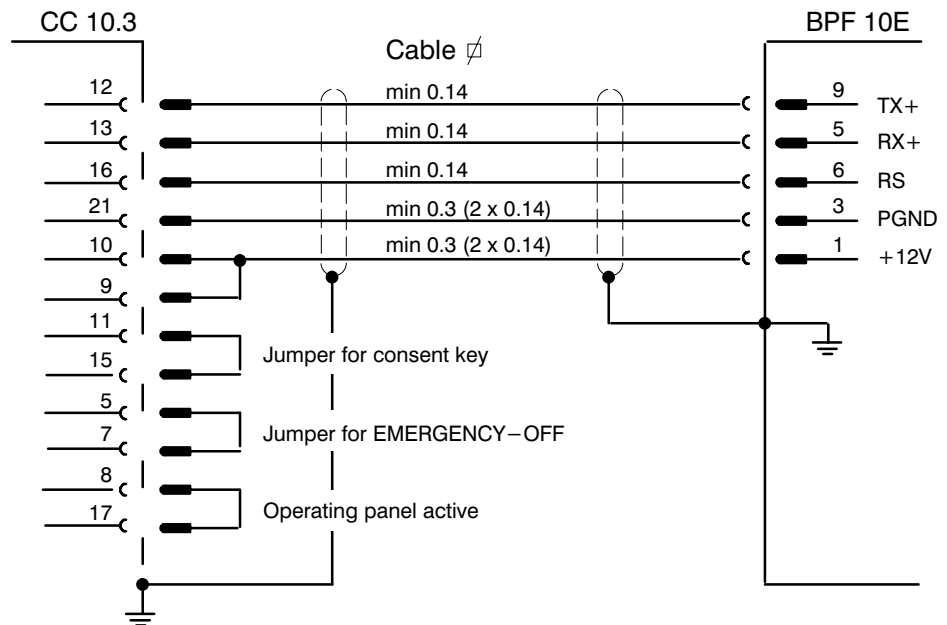

Fig. 3.2.2

There is neither a consent key nor an EMERGENCY-OFF switch for the BPF 10E. The BPF 10E can therefore be connected to the CC10.3 directly as well.

3.2.6 Ambient conditions

Operating temperature range: +5 to +45 degrees Celsius

Storage temperature range: +20 to +65 degrees Celsius

4. ELECTRICAL CONNECTIONS

4.1 General

The NC machine tool normally draws its power supply from the 3-phase mains. All internal voltages are derived from this mains supply. The relevant standards and regulations must be taken into account when establishing the mains supply.

The electrical connections specific to the CNC and PLC are described in the following section.

4.2 Power supply

The potential connection between all machine parts (especially between the CC 10 and drive units) must be kept as short as possible. All shields must be connected on both sides.

The relevant VDE regulations (e.g. VDE 0100) and the regulations issued by the local utility company must be taken into account.



DANGER

4.1

The relevant norms and procedures should be taken into account when connecting to the mains supply. The VDE standards (e.g. VDE 0100 and VDE 0113) and the regulations of the local power station should, in particular, be observed!

All connection cables are to be laid out as shown in the block diagrams. Work on electrical connection may only be carried out by appropriately qualified personnel.

Suitable electric tools should be used for this purpose. As a rule, transformers as defined by VDE 0551 must be used!

4.2.1 Power connection

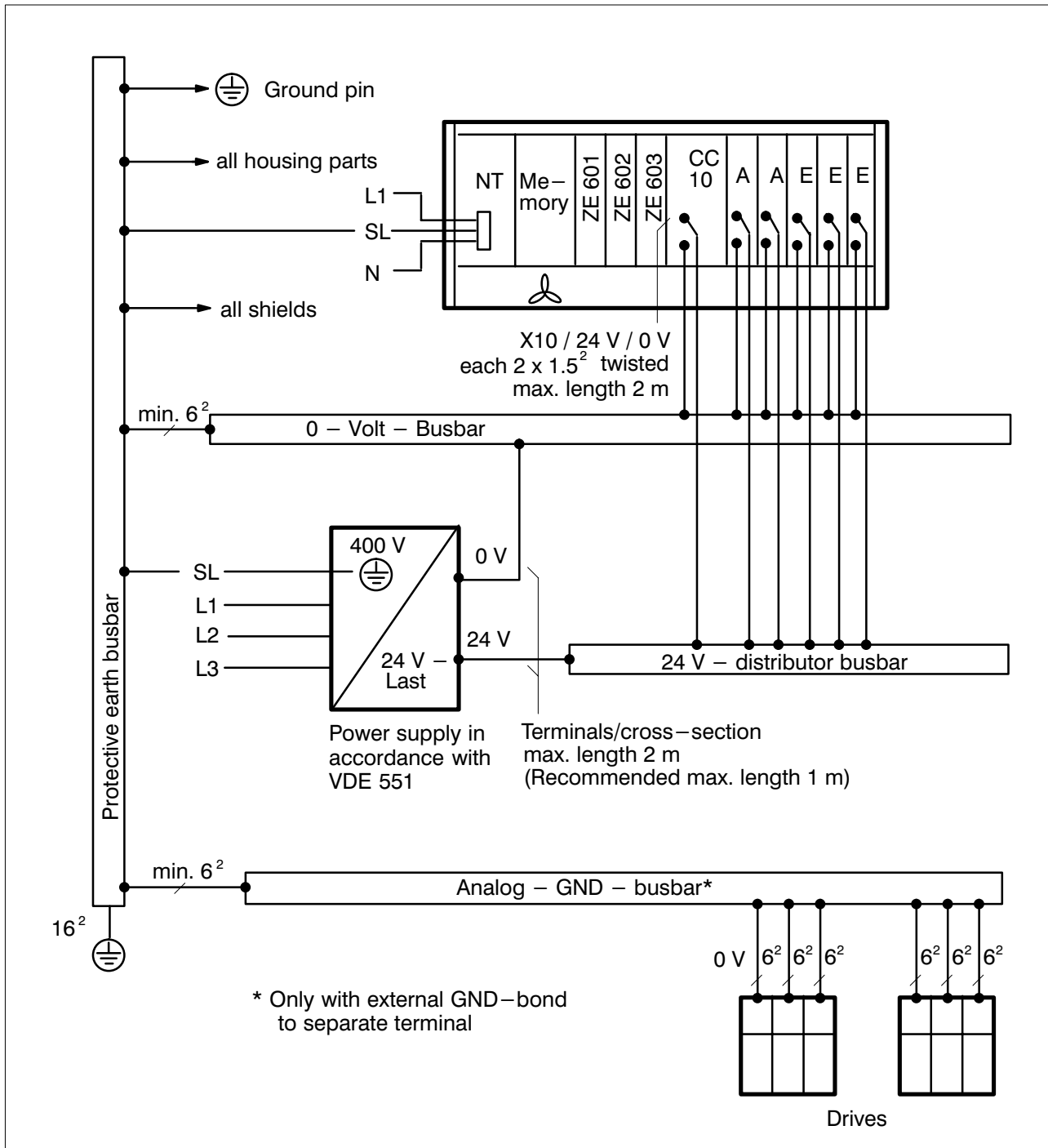

Fig. 4.2.1

Note:

No binding information can be provided with respect to grounding or GND wiring of the drive amplifiers. The drives must be wired in accordance with the manufacturer's specifications.

4.2.2 Input

Input voltage U _I :	24 V DC (+20.4 – +28.8 V)
Residual ripple at U(nom.):	refer to Fig. 4.2.2
Immunity to noise and destruction:	U _{max} = 35 V/t < 100 ms
Current consumption at U(nom.):	max. 2 A
Input fuse:	M 4 A (5 x 20) medium slow-blow
Protection against polarity reversal:	by means of decoupling diode. The input fuse is not tripped if the poles are reversed.
Power consumption:	nominal load and U(i) = 24 V < 50 W
Efficiency:	nominal load and U(i) = 20 V > 65 %

For load supplies: Overloaded a.c. components, resulting from an uncontrolled three-phase bridge connection without smoothing with a ripple factor (see DIN 40 110/10.75, section 1.2) of 5%, are permitted. This results in a highest absolute value of 30.2 V for the voltage upper limit and a lowest absolute value of 18.5 V for the lower limit.

The voltages for power supply with unregulated, unsmoothed three-phase bridge circuits are shown in the following diagrams.

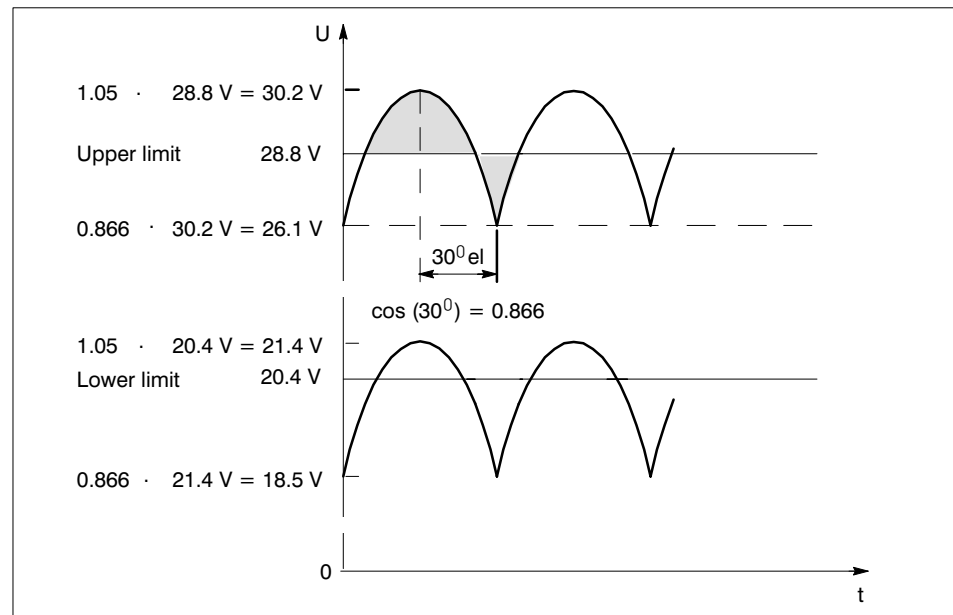

Fig. 4.2.2



CAUTION

4.2

With machines driven with mains voltage, it should be checked before set-up whether the preset/required mains voltage range is compatible with the local mains supply.

Fluctuations or deviations of the mains supply from the nominal value must not exceed or fall below the given tolerance limits. Otherwise, function failures and/or hazardous conditions at the electrical modules cannot be ruled out.

4.2.3 Output

All voltages are permanently short-circuit-proof. If the overvoltage protection of the +5.1 V supply is tripped, renewed switching on is possible only 60 seconds after deactivation of the input voltage. The input fuse is not tripped.

Max. interruption time at $U(\text{nom.}) 24 \text{ V} > 30 \text{ ms}$ every 10 sec.

Max. interruption time at $U(\text{nom.}) 20 \text{ V} > 20 \text{ ms}$ every 10 sec.

General error: In the event of a fault in one of the monitored internal voltages (+5 V, +/- 15 V, +12 V) or overtemperature, all voltages are switched off (general error active). Switching back on again is possible by first switching off the input voltage or by pressing the reset key.

4.3 PE Conductors and Screens

Originally, all PE conductors and 0V connections in a system were wired point-to-point and connected at only one earthing point to the switch cabinet housing. The screening of all measuring system, tacho or command cables was, in addition, only laid out on one side on an insulated earthing bar. A multiple branch, point-to-point screening system then developed from this. This wiring system held up well in the past, as the interference in the drive components was kept relatively low with thyristors commutating with 50 Hz or the transistors switching at low voltages (100 – 200V).

On the other hand, the of question of interference has been substantially changed with the introduction of voltage-source converters driven directly from the mains for high-dynamic speed regulation of feed and main spindle motors as well as the accompanying deployment of modern high-performance transistors.

Only a **screen laid out on two sides in conjunction with a heavily meshed earthing** can offer sufficient protection against unacceptable levels of interference!



CAUTION

4.3

The system's protective conductors (earth connections) must be configured machine – specifically!

Module housings, switching cabinet housings, assembly plates in the switching cabinet etc. must be connected to the protective conductor system. When wiring the protective conductors, it should be ensured that sufficient conductor cross section is present!

The equipotential bonding / PE leads of all system parts (particularly between NC and drives) must be kept as short as possible and therefore low – resistant. The resistance between the main protective conductor connection and all bodies of the equipment as well as of the machine must not exceed 0.1 (see EN 60204 part 1)!

All screens must be brought into contact on both sides – provided that the system configuration is an earthed electrical network.

For the screen conductors of drive setpoint leads, refer to the connection conditions of the individual drives for connection, as sometimes one – sided descriptions can be found there.

4.4 Interference suppression

4.4.1 General

Electrically operated and controlled machine systems can generate electromagnetic fields (high and low frequencies), causing mains disturbance. They must therefore be suppressed in accordance with existing regulations.

VDE 0874 Guidelines for radio–interference suppression.

VDE 0875–B and VDE 0871 Regulations for radio–interference suppression in equipment, machinery and plants at nominal frequencies between 0 and 10 kHz.

The appropriate interference–suppression measures have already been taken in BOSCH control systems. However, the operational reliability of a control system can be impaired by line–transmitted interference.

For this reason, the external wiring (control cabinet) includes

- filters
- spark–quenching circuits,
- attenuation of inductive switching peaks,
- limitation of the switching voltage of high–speed semiconductors and
- shields.

It is important to take all these components into account for interference suppression, since they yield an optimum and economic result only when combined.

The matter of electrical balance or unbalance is another important aspect. In addition to the balanced noise voltage components occurring between the mains power lines, unbalanced noise voltages may also occur as a result of, for example, capacitive coupling between the interference source and the mains. The following diagram illustrates a typical suppressor circuit. The unbalanced interference voltages are discharged to chassis via C_y . The balanced noise is attenuated by C_x .

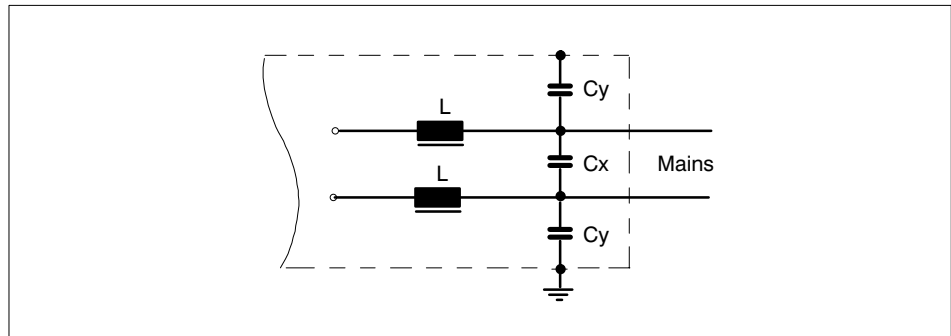

Fig. 4.4.1



CAUTION

4.4

- Interference suppressor as close as possible to the source of interference.
- Limit discharge currents according to safety regulations (contact protection!).
- Provide good mechanical support for interference suppression elements, in order to avoid a break through vibration.
- Use designated components only for interference suppression.

4.4.2 Examples

4.4.2.1 Contact circuit

(Alternating current, direct current, superimposed direct current)

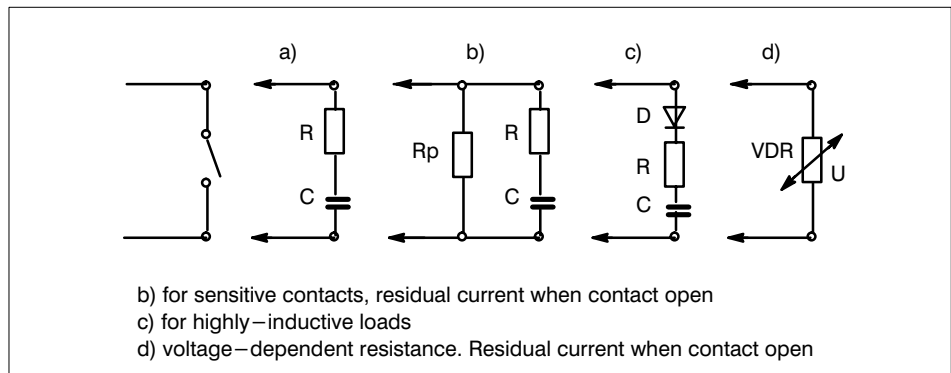

Fig. 4.4.2

4.4.2.2 Connecting an inductive load

(Motors, solenoid coils, relays and contactor coils)

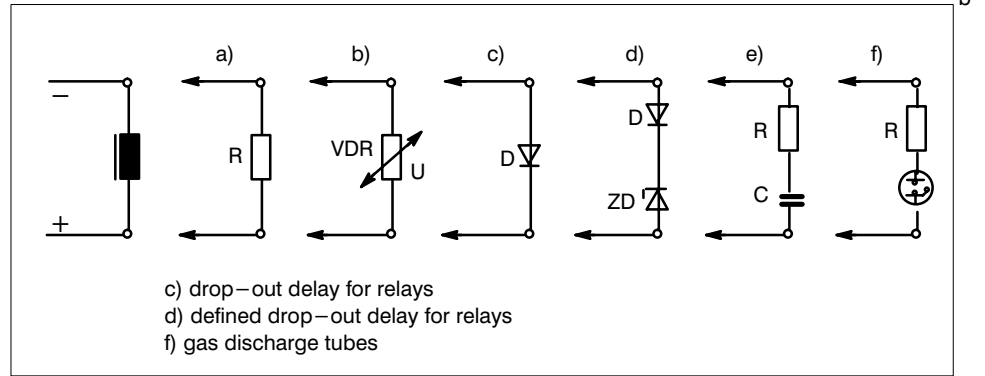

Fig. 4.4.3

4.4.2.3 Mains connection

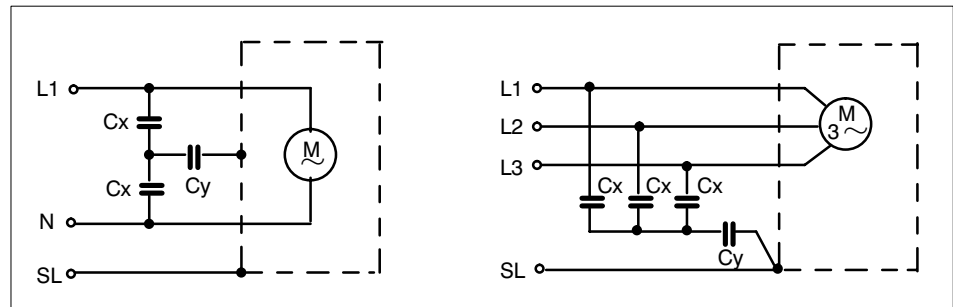

Fig. 4.4.4

4.5 Ready contact

A floating contact is brought out at terminal X10 on the front panel (see Chapter 2, Fig. 2.1.1).

This contact has the designation "Ready" and must be connected in the monitoring circuit of the overall system.

The contact is closed after the CC 10 has "run up" and if there is no internal control error or an error in the CC 10 periphery (e.g. measuring systems).

The contact is open if the power supply general error or another internal control error is pending.

In addition, the contact is opened if various errors occur in the peripheral devices, e.g. in the servo control loop.

The corresponding errors are identified in the description of error codes in Chapter 8.

The contact is closed again only when the corresponding error has been remedied and when the control system has been switched on and off again.

If the Ready contact was opened due to incorrect parameterisation, the compensation of the machine parameters with subsequent acceptance leads to run-up in the control system and the Ready contact being closed.

The following characteristic data apply to the contact:

Switching power:	$P_{\max} = 30 \text{ W}$
Switching current:	$I_{\max} = 0,8 \text{ A}$
Switching voltage:	$U_{\max} = 40 \text{ V DC}$

5. CONTROL LOOP INTERFACE

5.1 Overview

5.1.1 Control variant for incremental measuring systems

Those function elements not described here are identical with those described in Section 2.1.1

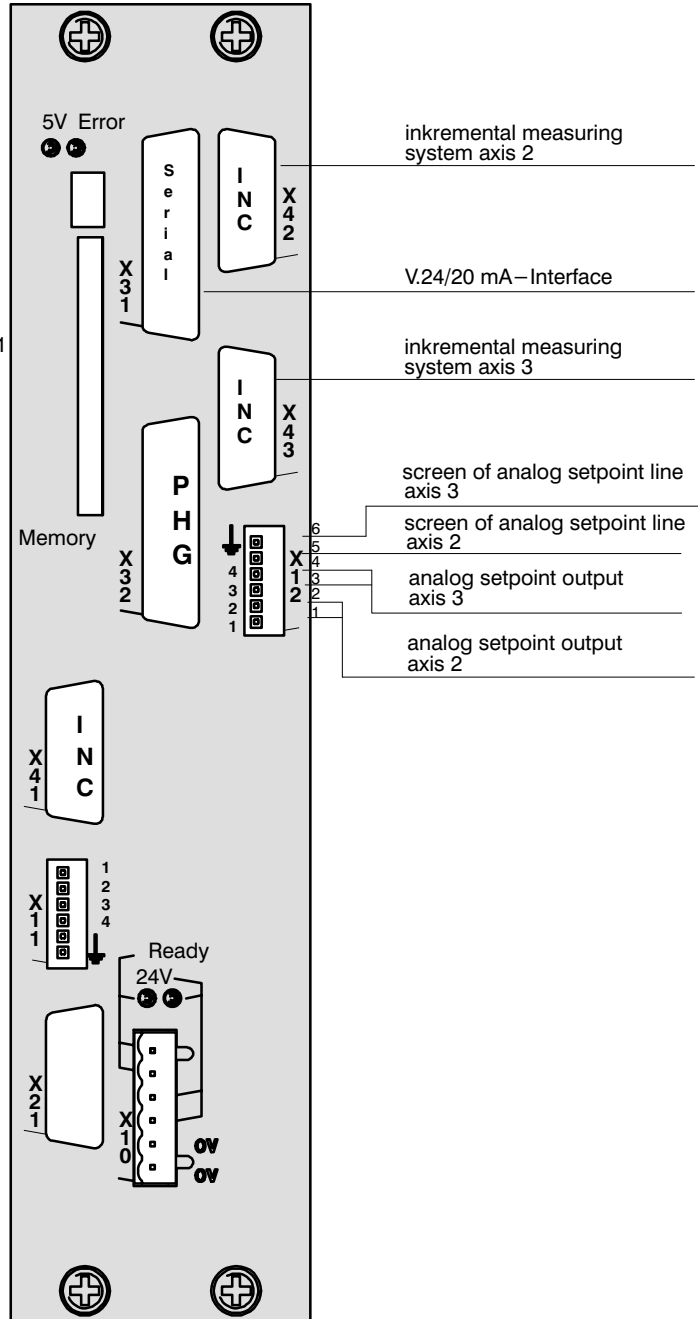

Fig. 5.1.1

5.1.2 Control variant for absolute measuring systems

Those function elements not described here are identical with those described in Section 2.1.1

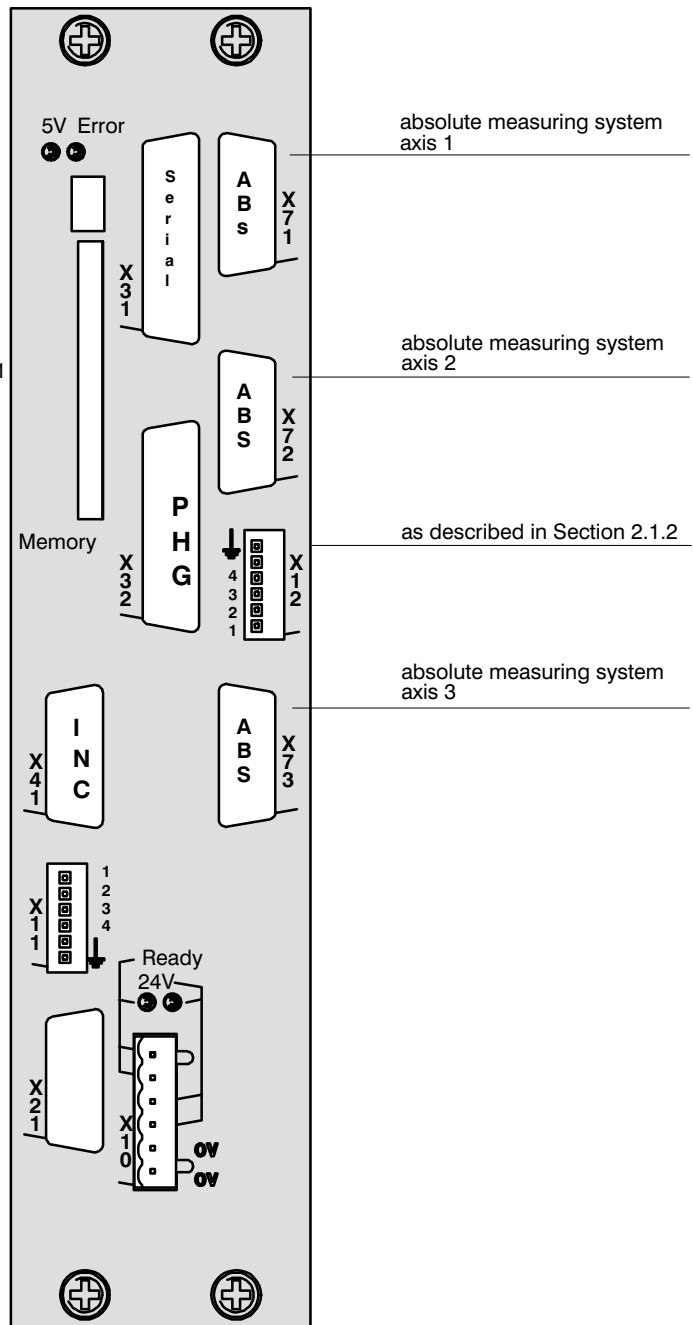

Fig. 5.1.2

5.2 Setpoint output

5.2.1 General

The CC 10 can drive a maximum of 3 servo-motors.

5.2.2 Technical data

Speed-proportional voltages are available at the setpoint outputs for controlling the individual axes.



CAUTION

5.1

The output levels of the CC10 are continually short-circuit-proof. If, however, several outputs are short-circuited, the increase in power loss may lead to the destruction of the output operation amplifier.



CAUTION

5.2

If the READY2 contact is opened, the setpoint outputs are set to 0V (analog-GND). This level is guaranteed for a maximum of 1 second! For this reason, the drives must be switched off within 1 second!

The following points should be observed concerning the analogue setpoint outputs of the CC10:

- Output voltage (rapid): ± 10 V
- Resolution: 1.6 mV
- The output voltages are non-floating.
- Permissible load resistance at output: min. 10 kOhms
- Reception cable type: Belden 2 x 0.5 mm (8762-20)
- Max. cable length: 50 m
- The screen connection is dependent on the drives used (e.g. for Servodyn T: two-way connection).
- The inputs to the drive amplifiers should be switched as difference amplifiers!
- Offset adjustment takes place via machine parameter 250.

5.2.3 Connecting servo-amplifiers

5.2.3.1 Connecting servo-amplifiers with differential input

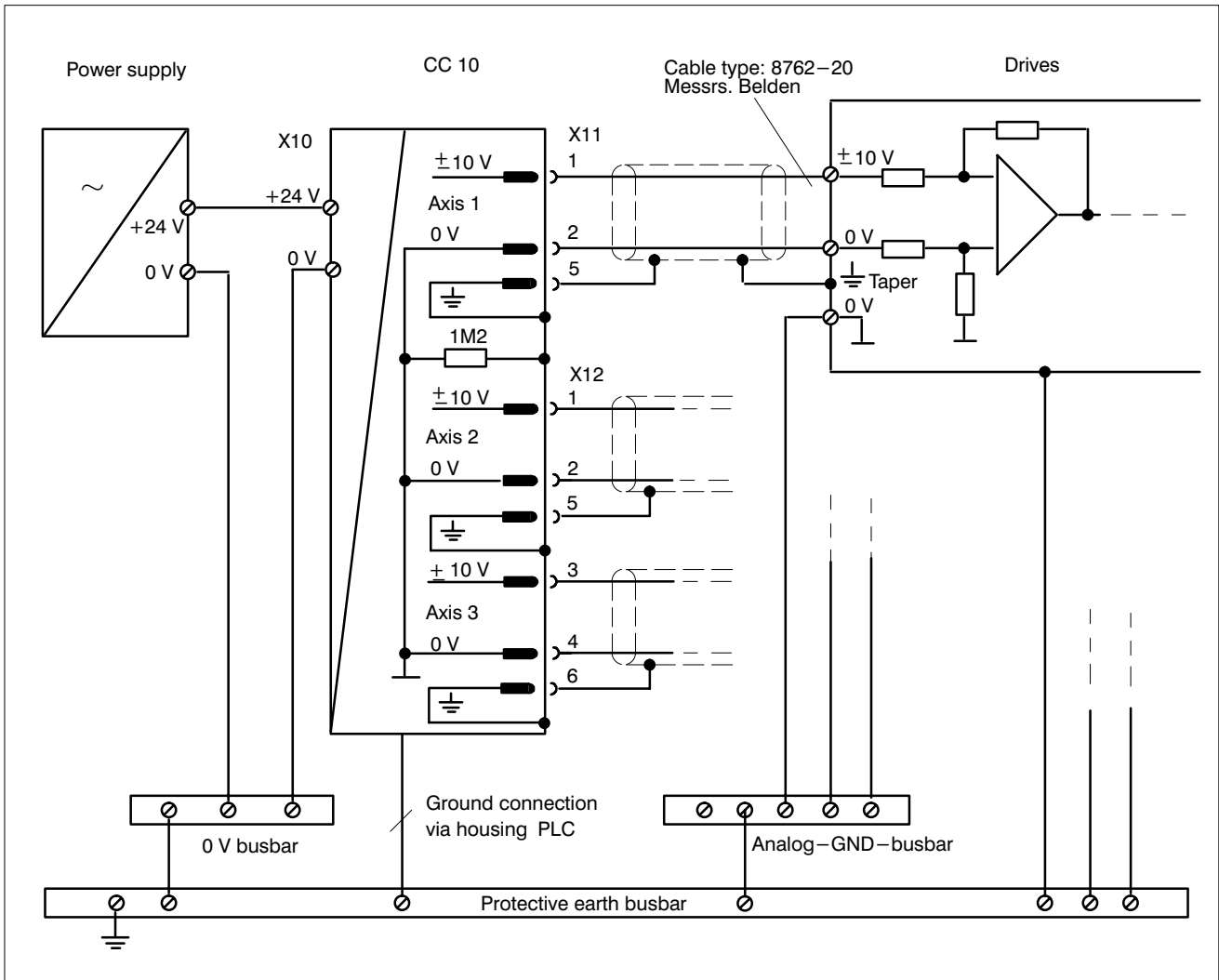

Fig. 5.2.3.1

Note:

No binding information can be provided with respect to GND wiring of the drive amplifiers. The drives must be wired in accordance with the manufacturer's specifications.

5.2.3.2 Connecting servo-amplifiers with differential input and GND in drive amplifier permanently connected with housing (e.g. Servodyn-TC)

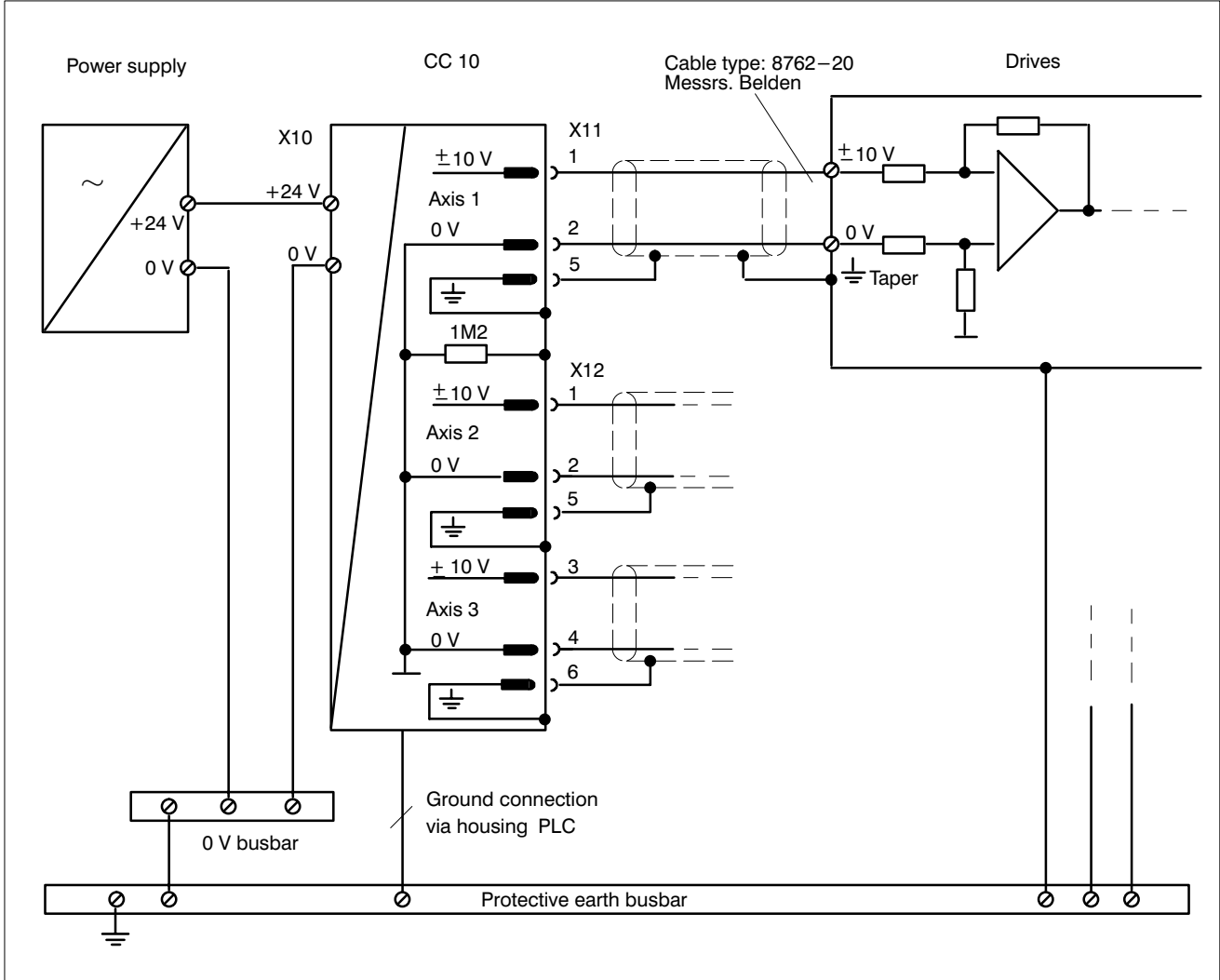

Fig. 5.2.3.2

Note:

No binding information can be provided with respect to GND wiring of the drive amplifiers. The drives must be wired in accordance with the manufacturer's instructions.

5.2.3.3 Connecting servo–amplifiers with GND input



CAUTION

5.3

Servo amplifiers with a GND–affected input must not be connected to the CC10.

5.2.3.4 Special features

Undefined voltages are output to the setpoint outputs during initialization of the CC 10 (after switching on until the D/A converters are first operated).

The last voltages output remain present at the setpoint outputs following a processor failure or failure of the regular update of the D/A converters.

The READY contact breaks in both cases. The READY contact must be linked in the monitoring circuit of the control cabinet (see Chapter 4.5).

5.3 Measuring systems

5.3.1 General

Each CC 10 has a maximum of 3 measuring system inputs for incremental measuring systems.

5.3.2 Technical data

Incremental measuring system

The incremental measuring system inputs are intended for connection of measuring systems with 5 V output signals.

General

- Max. cable length **axis 1**:
 - 35 m for a current consumption of the connected measuring system < 220 mA.
 - 25 m for a current consumption of the connected measuring system < 350 mA
 - 50 m + 20 m when using an EXE 8 XX with separate 220 V supply.
 - TYPE "TE60" measuring system (Messrs. Stegmann):
50 m – the cable length cannot be extended even by connecting an EXE unit.
- Max. cable lengths for **axes 2 & 3**:
 - The encoder supply of axis 2 is controlled via sensory circuits. Voltage delays in the encoder cables are thereby automatically compensated up to a length of 50 m.
 - Axis 3 is set automatically to the output voltage of the 2nd axis. The difference in cable lengths between the 2nd and 3rd axes may not exceed 15 m.
- Cable
 - NFS 72 64:
10 x 0.14 mm² + 4 x 0.5 mm²
- TTL input signals
 - A, B, R and their inverse signals.
- Pulse multiplication
 - The signals supplied by the measuring system are quadrupled in the CC 10.
- Max. permissible input frequency
 - 500 kHz

- Minimum slope interval between active counter pulses $a \geq 250 \text{ ns}$ (refer to Fig. 5.3.1)
- Min. slope interval for reversal of the direction of rotation $b \geq 0$ (refer to Fig. 5.3.1)
- Safety interval for reference signal $c \geq 100 \text{ ns}$ (refer to Fig. 5.3.1)
- Signal inputs Differential line receiver with $R_i = 120 \text{ Ohm}$ (min. voltage difference $R_i = 120 \text{ Ohm}$) (min. voltage difference between \bar{A} and $A \geq 600 \text{ mV}$).
- Encoder power supply +5.1 V at the NC output (corresponding to $5 \text{ V} \pm 5 \%$ at the encoder with the permitted cable lengths).
- Max. permissible current consumption per encoder 350 mA
- Max. permissible current consumption for all connected encoders per CC 10 660 mA

The signal lines for the measuring systems must be connected in accordance with the interface conditions. On account of the zero pulse decoding, the signal lines must not be reversed in order to obtain a reversal of direction. The counting direction is reversed via machine parameters P 260 and P 261.

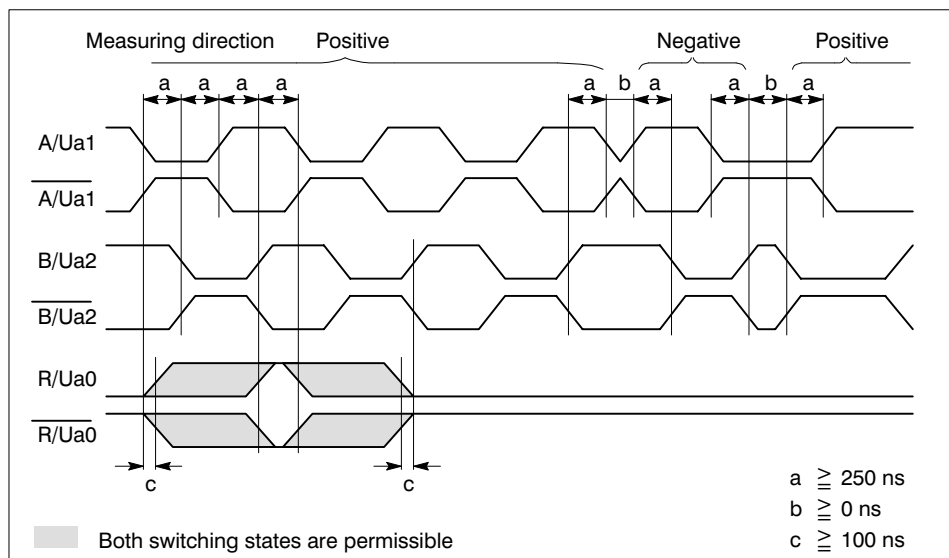

Fig. 5.3.1

5.3.3 Direct connection of measuring systems from Messrs. Heidenhain

The encoder cable between the CC 10 control system and ROD encoder can be supplied by BOSCH. The cable is fitted with a 15-pole D connector on the NC side and a 12-pole round socket of the type **SOURIAU** on the encoder side. If the ROD encoder is supplied by BOSCH, a **SOURIAU** round connector is connected to the flying leads (0.5 m). Preassembled encoder cables are available in lengths of 5 m, 8 m, 16 m, 25 m and 35 m.

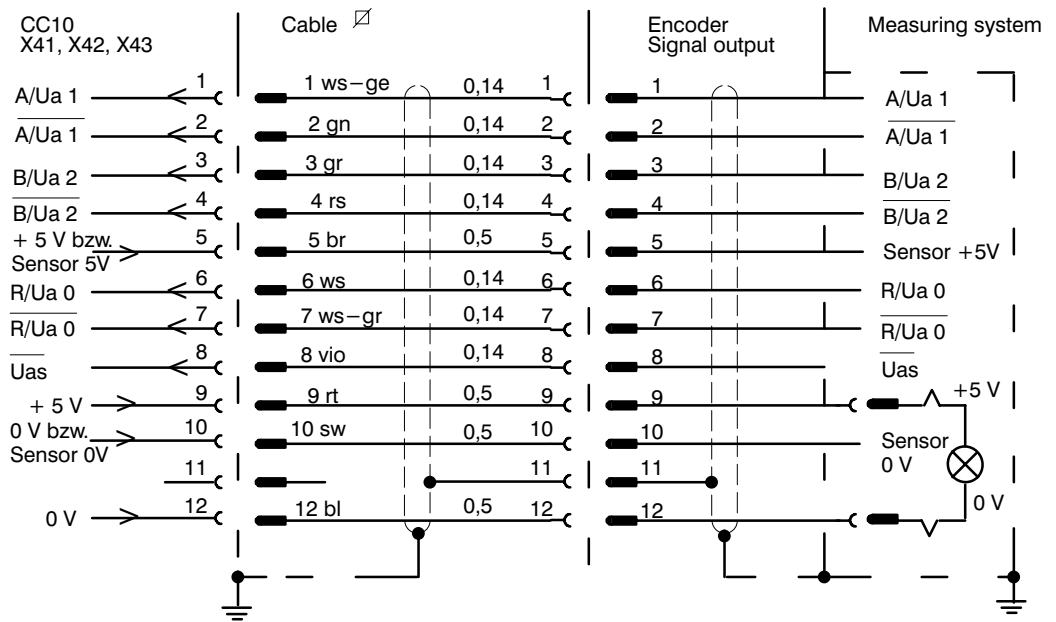
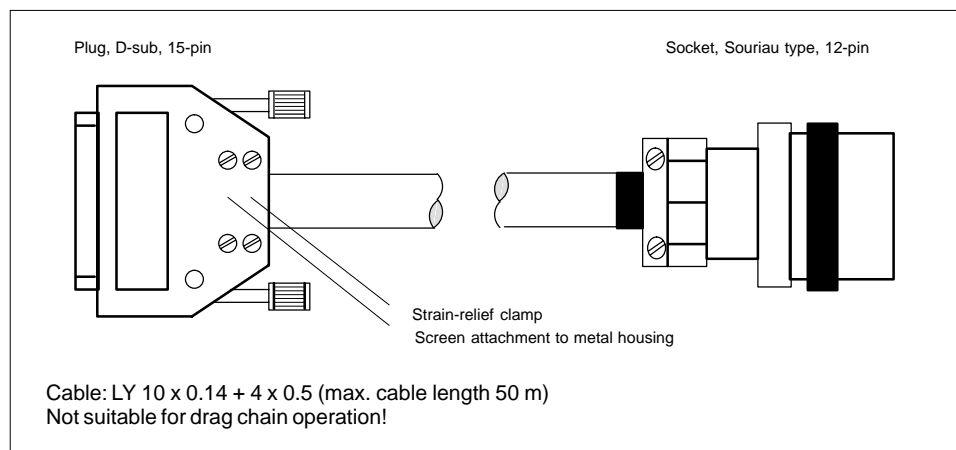

Fig. 5.3.2

Important

The pin assignment applies only to cables and encoders supplied by BOSCH.

Cable from Servo to Measuring System (ROD)



Plug Assignment

Colour	D-sub plug	Souriau socket
white-yellow	1	1
green	2	2
grey	3	3
pink	4	4
brown 0.5	5	5
white	6	6
white-grey	7	7
mauve	8	8
red 0.5	9	9
black 0.5	10	10
blue 0.5	12	12
Screen	plug housing	11

Ordering Information

Type	No.
Complete cable, cable length 5 m	048 663
Complete cable, cable length 8 m	048 270
Complete cable, cable length 16 m	048 664
Complete cable, cable length 25m	048 665
Complete cable, cable length 35 m	048 666
Complete cable, cable length 50 m	048 667
Components:	
Cable 10 x 0.14 + 4 x 0.5	903 499
D-plug 15-pin, pin904 440	904 440
Metal housing for 15-pin D-plug	913 724
Socket, 12-pin Souriau	909 131
Set of accessories for Souriau socket	909 688

5.3.4 Direct connection of measuring systems from Messrs. Stegmann

The encoder cable between the CC 10 control system and measuring system can be supplied by BOSCH. It is fitted with a 15-pole D connector on the NC side and a 12-pole round socket of the type **Souriau** on the encoder side.

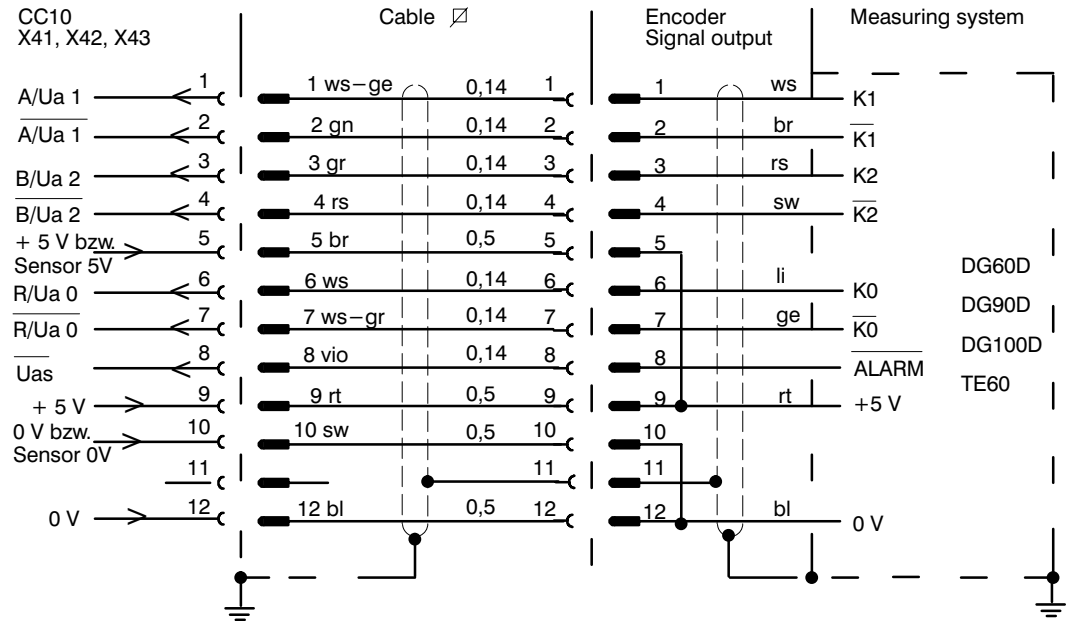

Fig. 5.3.3

Important

The pin assignment applies only to cables supplied by BOSCH. If the cable with housing type "K" supplied by Messrs. Stegmann is used instead of the cable supplied by BOSCH, the maximum cable length is 25 m.

Only the housing type "1" with a flying lead of 0.5 m must be used for the encoder in conjunction with the BOSCH cable. In this case, a 12-pin SOURIAU round connector must be fitted to the encoder by the user.

5.3.5 Connecting measuring systems from Messrs. Heidenhain with EXE unit

The encoder cable between the CC 10 control system and EXE can be supplied by BOSCH. It is fitted with 15–pole D connector on the NC side and a 12–pole round socket of the type SOURIAU on the EXE side. Pre–assembled encoder cables are available in lengths of 5 m, 8 m, 16 m, 25 m and 35 m.

If the EXE is supplied by BOSCH (EXE 604C), a SOURIAU round connector is connected to the flying lead (0.5 m). No more than two plug connections are permitted between the EXE unit and encoder.

Original **Heidenhain** cables are used to connect the EXE and measuring system. EXE units with tri–state outputs should preferably be used.

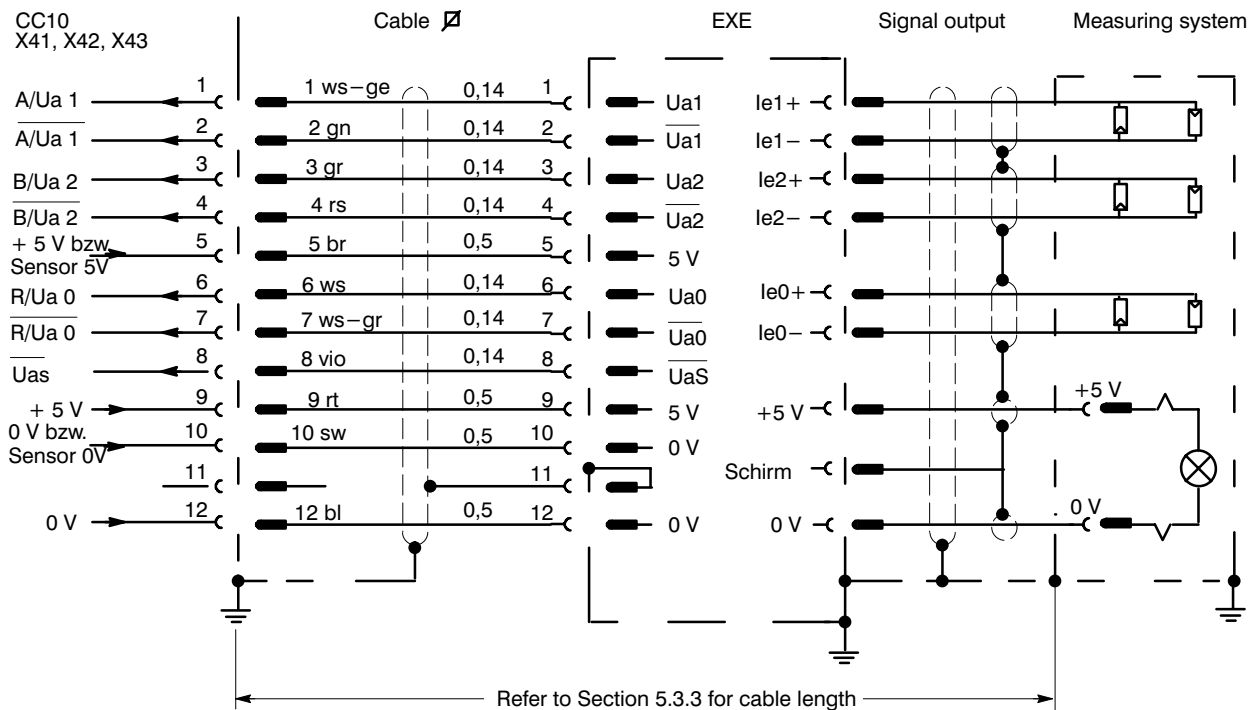

Fig. 5.3.2

Important

The pin assignment applies only to cables and EXE units supplied by BOSCH. Pins 5 and 9 (5 V) are not wired if an EXE 8xx with separate 220 V supply is used. The pin assignment and interface conditions for these EXE units can be found in the documentation supplied by the manufacturer, Messrs. Heidenhain.

5.3.6 Shorting plug for measuring system input (applies only to incremental measuring system)

The shorting plug is used to test the measuring circuit without connected measuring system.

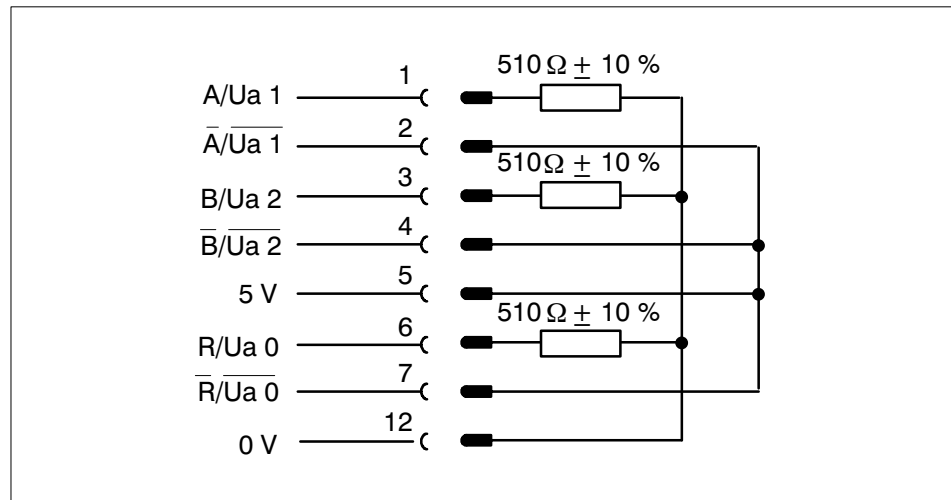

Fig. 5.3.5

5.3.7 Permissible digital measuring systems

The combinations of ROD/LS and EXE units supplied by Messrs. Heidenhain must be adapted in accordance with the requirements of the machine and control system. The manufacturer's interface conditions (routing and cable length) must be observed.

Rotary encoders from Messrs. Stegmann can be used only in conjunction with the following electrical parameters:

- Square-wave signal output
- Circuit output driver in accordance with EIA 485 A (code letter F)
- Power supply $U(s) = 5 \text{ V}$.

Permissible encoder types are listed under the description of rotational measuring systems.

The current consumption of the connected measuring systems or EXE units and measuring systems must not exceed the maximum permissible total current output of the CC 10; if necessary, the CC 10 must be used with a lower number of axes or EXE units with separate 220 V supply must be used.

On account of the frequency with which measuring systems are modified and the growing variety of types, the list of measuring systems can be no more than a general recommendation.

Rotational measuring systems:

- Rotary encoder for direct connection
(Heidenhain) : ROD 220, (420), (426), 428
(Stegmann) : DG60D, DG90D, DG100D, TE60
- Rotary encoder for connection via EXE 604C, 605: ROD 250, 450, 456, 700
- Rotary encoder for connection via EXE 816: ROD 800

Linear measuring systems:

- Linear scales for connection to EXE 604 C, 605, 610, 801, 802, 803, 804, 805, 813: LS 703

Please consult BOSCH before using other measuring systems.

5.3.8 Recommended pulse-shaper electronics (EXE) and encoder

We recommend the use of an EXE 604 C and ROD 428 encoder. These types do not have any capacitive connection between the 0 V line of the supply voltage and the housing, leading to higher interference immunity. In addition, these types have an extended measuring system monitoring function which reports errors to the CC 10 by tri-state switching of the output signals. Ensure that this tri-state function is activated when using an EXE 604 C (jumper inserted); if necessary, include an appropriate reference when ordering the EXE.

The EXE 604 C has been specially developed for BOSCH control systems. It corresponds with the EXE 601, but has an additional grounding pin and a 12-pole SOU-RIAU connector on the NC side.

The ROD 428 encoder offers considerably greater safety and reliability than other encoder types made by Messrs. Heidenhain.

Important

The CC10 detects a measuring system error via the input signal Uas as well as through the connected encoders/EXE switching their output levels to tristate status (high-resistance).



CAUTION

5.4

When using an EXE or an encoder for a direct connection with a Uas signal, check that the wiring of the Uas signal to the CC10 is correct!

Open Uas inputs are placed at high potential by internal pull-up resistors (no measuring system error present).

5.3.9 Revolution-coded incremental encoder to TE60

5.3.9.1 General function description of the encoder

With regard to the signals, the to TE60 must be treated as an incremental encoder.

However, the difference between the to TE60 and an ordinary incremental encoder lies in the additional absolute disks subordinate to the incremental disk. The counted disk pulses are passed to a control logic within the encoder. In accordance with the number of revolutions and at a defined counter value, the control logic adds a supplementary pulse (marker) to the reference pulse for each revolution.

This point advances by one increment with every revolution. The absolute position referred to the zero point of the encoder can be determined on the basis of the distance between the two markers. The absolute position referred to a displacement is determined by adding an offset which must be calculated beforehand. Once the absolute position has been determined, the encoder is treated in the same way as an incremental encoder.

5.3.9.2 Limits set by the encoder

The length of travel is limited by the encoder. The maximum travel in pulses is calculated from the maximum number of encoder revolutions and the number of encoder scale divisions multiplied by 4 (refer to the description of machine parameter P203).

5.3.9.3 Start-up cycle

The start-up cycle is treated and started in the same way as "Approach reference point". In contrast to conventional incremental encoders, however, it is not necessary to travel to a "reference point cam" with subsequent synchronization.

The absolute position is determined by the CC 10's operating software in the course of one encoder revolution.

5.3.10 Monitors

Correct functioning of the measuring systems connected is constantly monitored by a number of system monitors:

The mutuality of the encoder output signals is monitored by the hardware. Error flags are polled by the software. The following errors can be identified, for example:

- measuring system not connected,
- cable breakage,
- short-circuit,
- failure of the encoder supply voltage,
- internal error states in the encoder resulting in tri-state switching of the encoder output signals (e.g. ROD 428)

The number of pulses between two reference markers (per revolution in the case of encoders) is monitored by the software. The following errors are detected:

- loss of counter pulses (e.g. due to faults),
- additional counter pulses (e.g. generated by faults),
- failure of the reference signal.

If any of these monitors is tripped, the state is stored by the CC 10 and the READY contact breaks.

After remedying the cause of the faults, an error message can only be cancelled in one of the following ways:

- switching the power supply of the CC 10 off and on again
- or
- setting the input signal I 0.5 RESTART.

5.4 Absolute measuring systems

5.4.1 General

A maximum of 3 axes can be operated with closed-loop position control per CC 10. The CC 10 for absolute measuring systems (designation: CC 10.2 ABS – V.24/20 mA) is available only as a "3-axis version". (Refer to Chapter 2.1.3.) In conjunction with this control, the 1st axis can be operated optionally as an incremental or absolute axis.

The connection for an *incremental* 1st axis is made at connector X81.

The connection for an *absolute* 1st axis must be made at connector X811.

The absolute value encoders are divided into

- single-turn encoders
- multi-turn encoders

In contrast to a multi-turn encoder, a single-turn encoder cannot count the number of encoder revolutions. A multi-turn encoder, on the other hand, also supplies a value for the number of shaft revolutions (setting via parameter P204) in addition to a value for the angle position (0°...360°).

The interface for an absolute encoder consists only of four data lines for the signals "LOOP-OUT" and "LOOP-IN" as well as two lines for the encoder power supply. Serial transmission takes place by output of a defined number of clock pulses (LOOP-OUT) to the encoder. The latter sends back one data bit via the data line (LOOP-IN) with every rising edge of the clock signal. Since the encoder automatically inserts leading and trailing "0" bits, the fixed transmission format is independent of the encoder revolution.

It is possible to choose between single and double polling by means of parameter P206.

In the case of single polling, the number of clock pulses is as follows:

- single-turn: 14 clock pulses
- multi-turn: 26 clock pulses

In the case of double polling, the CC 10 defines 28 clock pulses for the single-turn encoder and 52 clock pulses for the multi-turn encoder. The shift register of the encoder is read out twice successively by the 28 or 52 clock pulses (the clock frequency is defined by the CC 10).

The serial data stream may occur in GRAY or BINARY format, depending on the encoder type. Definition with parameter P205.

5.4.2 Technical data

Absolute measuring system

Data transfer between the absolute measuring system and CC 10 and vice versa is performed via a serial data line (SSI interface). The serial data stream is converted internally by the control.

Interface characteristics CC 10

Max. cable length

Max. cable length 180 m, if the input circuit of the encoder electronics corresponds with the diagram in Fig. 4.4.1 (e.g. Messrs. Stegmann, type AG 66 SSI or AG 101 SSI) and the Bosch special cable, Order No. 070/912687, is used.

Note:

The encoder of Messrs. T+R, type CE65M has a different input circuit; this results in a maximum cable length of 80 m.

Cable

LIYCY 2 x 0.5 mm² + 3 x (2 x 0.14 mm²)

Clock frequency

~200 kHz

Clock pulses (clock bundle)

14 (28*) clock pulses, including powerfail bit for single-turn encoder

26 (52*) clock pulses, including powerfail bit for multi-turn encoder

* applies to double polling

Note:

A mixture of encoders with single polling and encoders with double polling is not permitted within one CC 10 module.

Resolution per revolution

max. 4096 steps/360 degrees

Number of revolutions

1 (for single-turn) to 4096_{max} (for multi-turn)

Code

Gray or binary

Monoflop time

+13 = 15...30 μ s
(refer to Fig. 4.4.2)

Encoder power supply

The specifications of the encoder supplier must be observed under all circumstances. If the specifications of the encoder supplier deviate from the characteristic data of the power supply (refer to Chapter 3.2.2), the voltage must be supplied separately (not via the CC 10) by means of a suitable power pack.

Loop out CC 10 and encoder

Driver in accordance with I/O standard RS-422 A
(Output voltage $U_A = 3.4 \text{ V} \dots 5 \text{ V}$)

Loop in CC 10 and encoder

Opto-decoupled
(Input current $I_F = 7 \text{ mA} \dots 20 \text{ mA}$)

Interface

Synchronous serial

Note:

The specifications of the encoder supplier must be observed additionally to the listed characteristic values.

It must be ensured that the traversing range of the measuring system is observed under all circumstances.

This means that the maximum traversing range of an axis must be within the traversing range of the measuring system.

Example:

A multi-turn encoder has 256 revolutions and a resolution of 512 steps per 360°
→ max. steps = 512 steps • 256
= 131072 steps

The traversing range is thus between 0 and 131072 steps.

The measuring system must be correspondingly rotated upon commissioning.

The following applies: $0 < \text{traversing range} < 131072$.

5.4.3 Connection of the measuring system

The cable for connection of the measuring system (not pre-assembled) can be supplied by Bosch.

Order No.: 912687

Designation: LIYCY 2 x 0.5 mm² + 3 x (2 x 0.14 mm²)

The connector for connection of the cable to the CC 10 is also available from Bosch.

D connector 15-pole

Order No.: 904443

Metal cover for D connector

Order No.: 913724

The voltage supply +24 V can be routed through the CC 10. Pin 14 of connectors X811, X812, X813 must not be used in each case if an external power supply is used.

Precondition:

The characteristic values of the power pack for the CC 10 must comply with the requirements of the encoder type used.

If this cannot be guaranteed by the user, the encoder power supply must be provided by a suitable external power pack. Only one coupling in the cable is permitted per encoder. The ground and screen connections must be looped through. If several measuring system cables are laid together, the metal housings of the couplings must be insulated with respect to each other. The order of axis assignment is defined: X71 for the 1st axis, X72 for the 2nd axis and X73 for the 3rd axis. It is possible to equip the first axis with an incremental encoder (machine parameter P201). In this case, the encoder is connected to connector X41.

The connector X71 remains unused in this case; it cannot be used for an additional axis.

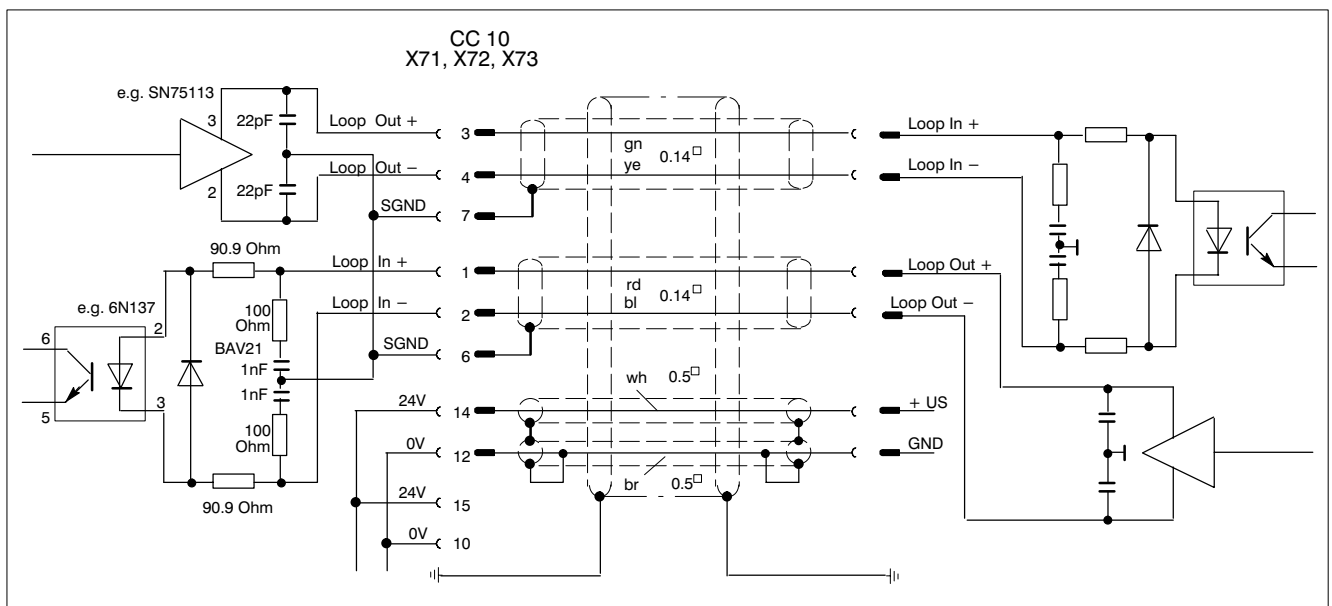

Fig. 5.4.1

5.4.4 Functional description of the interface

Compared with incremental encoders, absolute encoders have the advantage that the absolute axis position can be read by the control after the system is switched on. Owing to this possibility, travel to and synchronization at the reference point is not necessary.

The data (positions) are transmitted by the encoder to the CC 10 on the "Loop in" lines after a request (clock pulse) via the "Loop out" lines of the CC 10. The number of clock pulses issued by the CC 10 is defined irrespective of the encoder resolution.

Transmission occurs in accordance with a defined format (refer to, for example, 5.4.4.1).

A distinction is always made between single-turn encoders and multi-turn encoders as well as single polling and double polling.

Double polling (can be defined at the CC 10 by parameter) is not possible in conjunction with every absolute encoder.

A pre-condition for double polling in the encoder is ring buffer operation of the shift register. The encoder manufacturers will provide information here.

Insofar as the encoder permits double polling (= interrogation of the same position value twice in succession), this function should be used to increase the reliability of data transfer.

5.4.4.1 Data transfer for single-turn encoders (refer to Fig. 5.4.2)

At the time t_0 , the encoder is made to record and store the instantaneous position (angle position of the encoder) by the falling edge of the clock pulse.

At the same time, a monoflop in the encoder is triggered by each falling edge of the clock pulse. The monoflop time must be $15 \mu\text{s} \leq t_3 \leq 30 \mu\text{s}$.

The CC 10 outputs a rising edge after the time t_1 . The rising edge causes the encoder to transfer the 1st data item to the CC 10 (loop in). The 1st data item is the most significant bit (MSB) and possesses a value of 2^{11} . The CC 10 then outputs a falling edge after the time t_2 . The falling edge marks the end of the 1st clock pulse and the start of the 2nd clock pulse. The 1st data item 2^{11} is accepted by the CC 10 simultaneously with the falling edge.

The 2nd data item with the value 2^{10} is sent to the CC 10 with the next rising edge and the procedure as described above is repeated. The last data item to be transmitted is a power failure bit.

This bit is normally logical 0 and is set to logical 1 by the encoder if there is a fault in the encoder. This bit is evaluated correspondingly in the CC 10 (error display, breaking of the "Ready contact" at connector X10).

When the power failure bit has been received, transfer of a complete record in conjunction with single polling has been completed.

In the case of single polling, a few additional clock pulses are output by the CC 10 after clock pulse 14 (26) for single–turn (multi–turn) encoders. (Reason: uniform software structure for single and multi–turn encoders). These clock pulses are no longer relevant for data transfer. After transmission of the last clock pulse, the monoflop in the encoder is no longer retriggered and the monoflop time t_3 runs down. When this time has expired at the time t_5 , the data line from the encoder to the CC 10 (loop in) is switched to high level. This level is checked by the CC 10 before the start of each transmission (cable breakage detection).

The CC 10 can abort the clock pulse at any position without interfering with the operation of the encoder.

The time $t_4 > 35 \mu\text{s}$ is necessary in order to ensure that the loop–in line from the encoder to the CC 10 is switched to high level.

Only if this is guaranteed can a new position value be transmitted by the encoder at the time t_6 .

Special features in conjunction with double polling

Unlike single polling, clock pulse 14 has the same time characteristic as clock pulses 1 to 13 in the case of double polling.

In other words, the monoflop in the encoder is restarted and the time t_3 does not run down.

The data information which is transmitted during clock pulse 14 must possess the value 0 (0 bit).

Clock pulse 15 causes the encoder to send the already output data to the CC 10 again (ring buffer operation).

The monoflop time expires only with clock pulse 28 and the pause which the encoder requires to detect a new position is active.

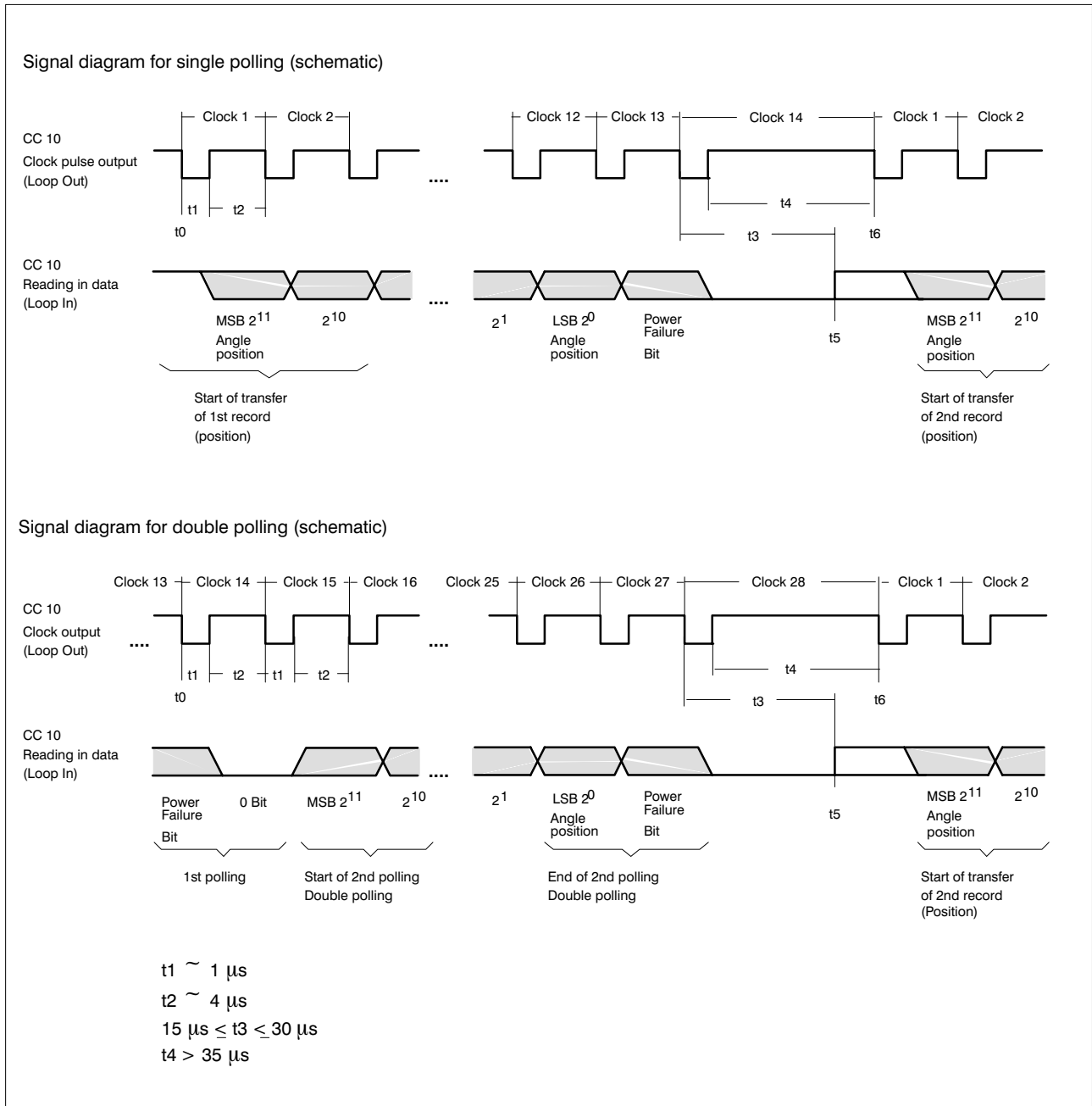

Fig. 5.4.2

5.4.4.2 Data transfer for multi-turn encoders

If a multi-turn encoder is used, the number of revolutions is additionally transmitted alongside the information for the angle position of the encoder within 360°. The format and time characteristic for transfer of the number of revolutions is the same as that for transfer of the angle position (within 360°). During clock pulses 1...12, the number of revolutions is transmitted by the encoder. The angle position within 360° and the power failure bit are transmitted during clock pulses 13...25.

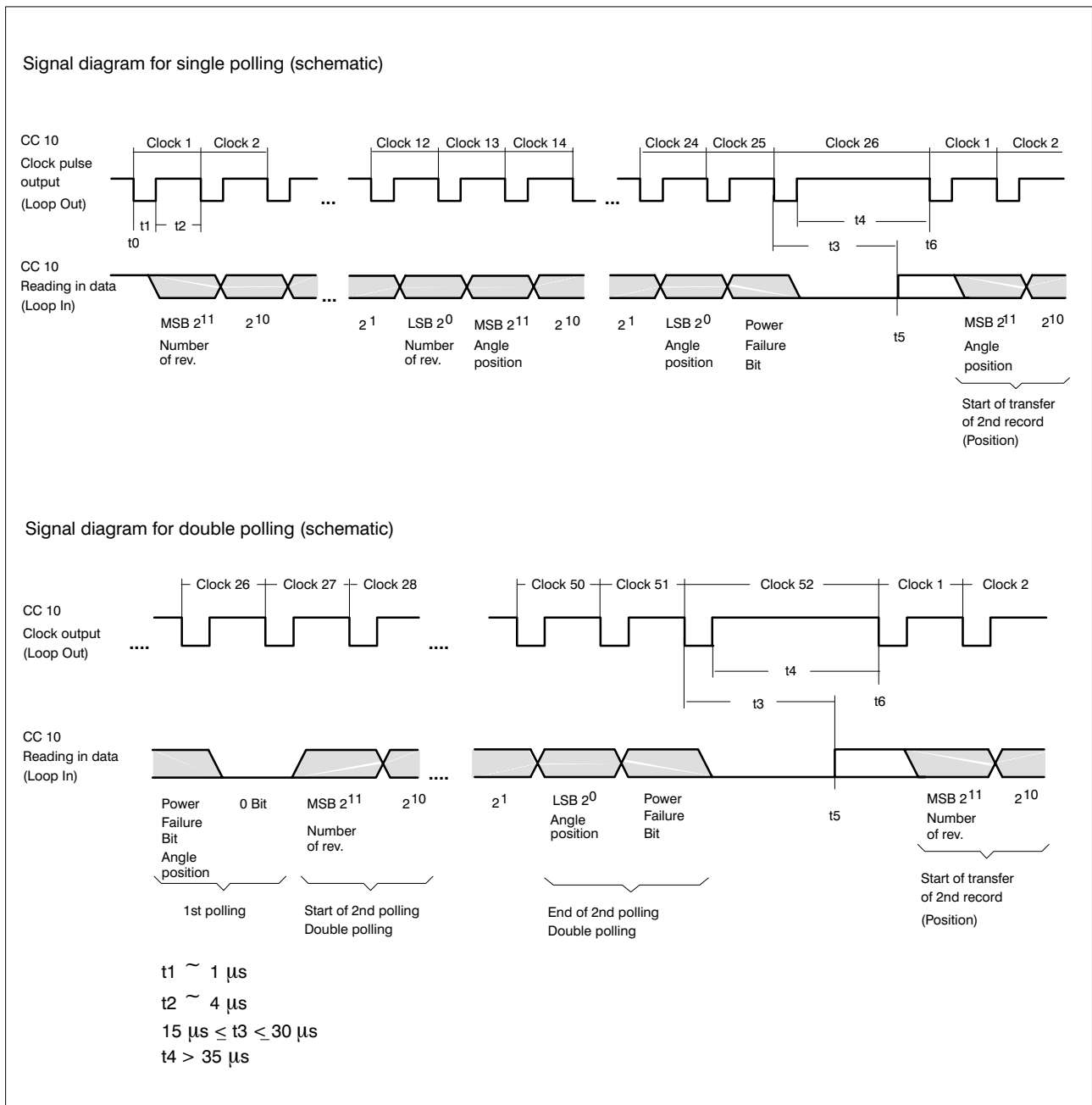

Fig. 5.4.3

5.4.5 Monitors

The functions of the connected measuring systems are continually checked by various monitors.

Cable breakage monitoring

The CC 10 checks the level of the Loop In data line at the time t_0 . The level must be high. In the event of a fault, the Ready contact is opened.

Plausibility check (only for double polling)

Faults on the serial data line can be detected by double polling. In the event of a fault, the Ready contact is opened.

Monitoring of the encoder supply voltage

If the encoder possesses a monitoring function for its supply voltage, it is possible to indicate this state by setting the power failure bit of the CC 10. In the event of a fault, the Ready contact is opened.

Other monitoring functions independent of the encoder type

Axis in movement

If a travel command exists, a change in position must take place within a given time (can be defined in machine parameter P208). In the event of a fault, the Ready contact is opened.

Axis at standstill

If the actual position deviates from the nominal position for a time longer than defined in the machine parameter P209 (distance programmable in machine parameter P207), the Ready contact is also opened.

A pending error message can be cleared after remedying the fault only by way of the following measures:

- Switching the power supply of the CC 10 off and on
- or
- setting the input signal E 0.5 RESTART.

6. DATA INTERFACES

6.1 Overview

The CC 10 control system has two data interfaces. They are used for communication with the control panel BPF 10 (E) as well as peripheral devices and higher-ranking computers. They provide the transmit and receive lines TXD and RXD as well as two control lines DTR and DSR.

Those function elements not described here are identical with those described in Section 2.1.1

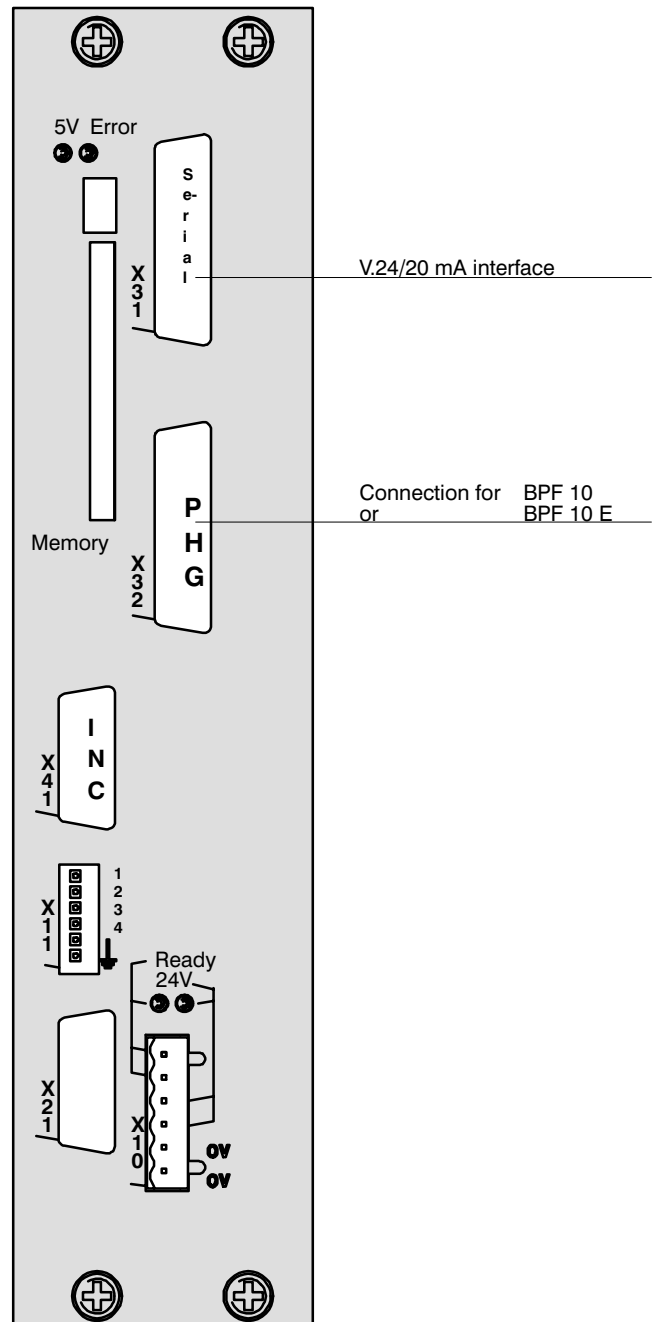

Fig. 6.1

6.2 Serial interface V.24/20 mA

6.2.1 General description

Socket **X31** includes a V.24 interface to CCITT recommendations (EIA-RS 232C) combined with a 20 mA current interface.

These interfaces can be operated at different transmission rates. The required baud rate and the connected data terminal are determined via the machine parameters of "device selection" on the BPF 10.

6.2.2 V.24 interface

Pin assignment

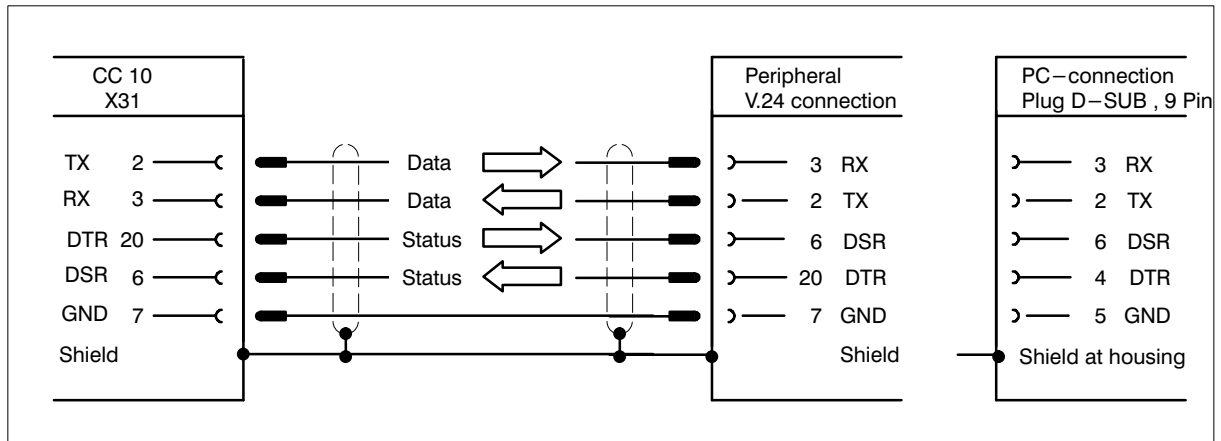

Fig. 6.2.1

The shield is connected to the plug connector via the metal housing on the control side.

Interface characteristics

- Cable length: max. 15 m
- Transmission rate: max. 4800 baud
- Signal level: high: +3 V to +12 V
low: -3 V to -12 V

6.2.3 20 mA interface

Pin assignment

The 20 mA interface can be operated as an active or passive interface. This results in two different pin assignments (active/passive).

Active interface

In active condition, the 20 mA interface of the CC 10 acts as a current source.

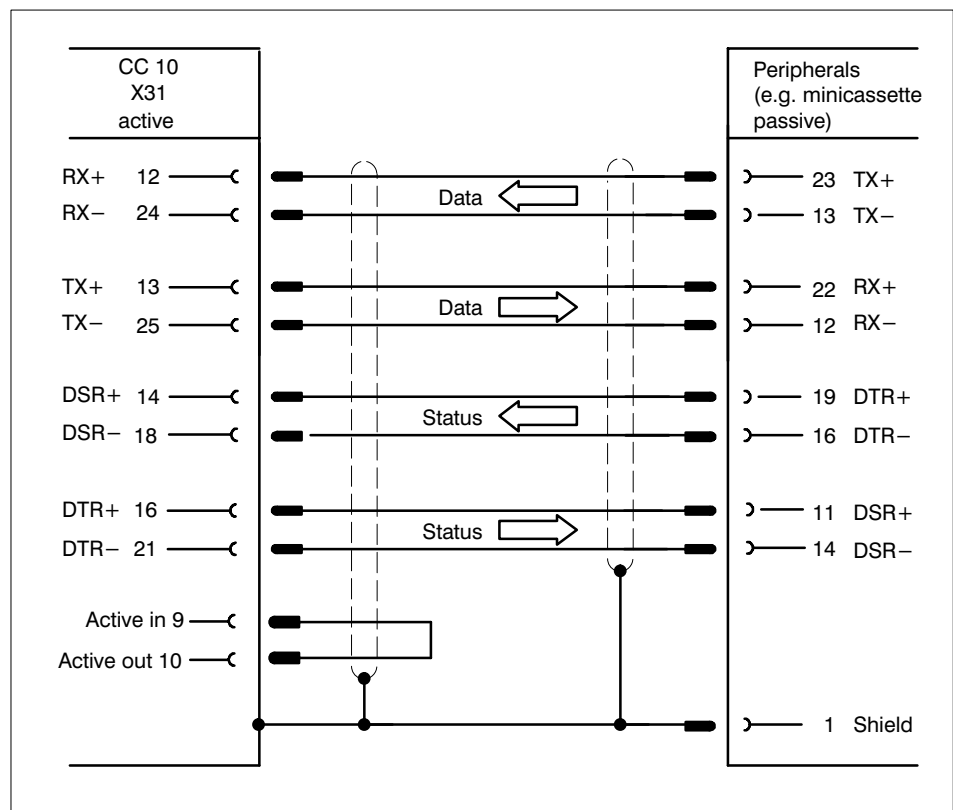

Fig. 6.2.2

Passive interface

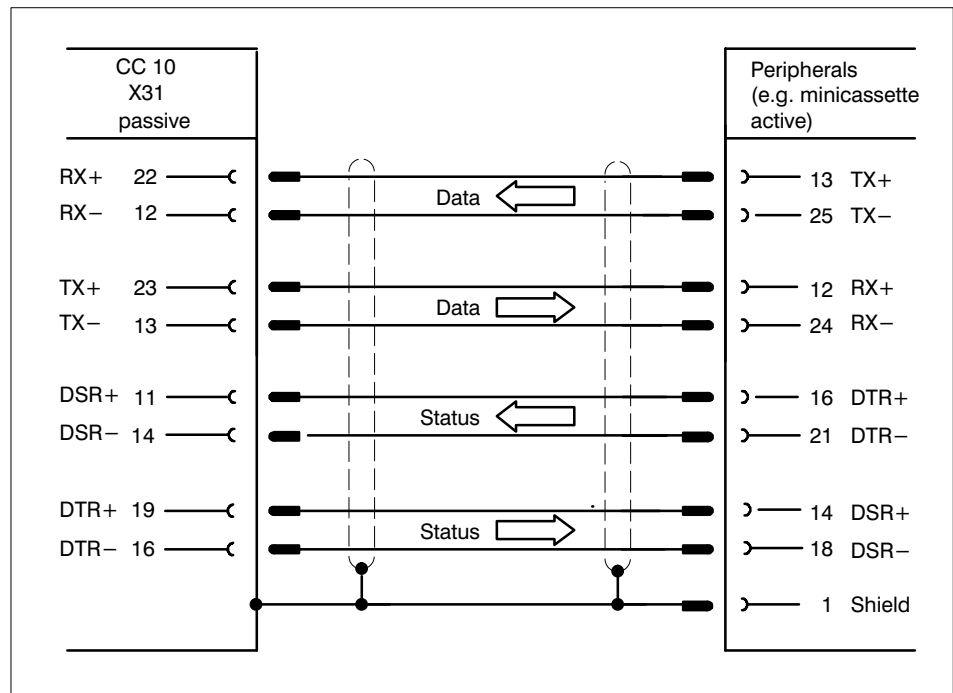

Fig. 6.2.3

The shield is connected via the metal housing of the connector on the control side.

Interface characteristics

Cable length:	depending on the transmission rate and ambient conditions.	
	The following can be seen as guide values:	
	CC 10 active:	max. 15 m
	CC 10 passive:	max. 100 m
Transmission rate:	with handshake	max. 4800 baud
	without handshake	max. 300 baud
Signal level:	high	approx. 20 mA
	low	approx. 0–2 mA
Voltage drop:	CC 10 active	the voltage drop must not exceed max. 2 V in the passive peripheral device.
	CC 10 passive	the voltage drop must not exceed max. 2 V in the CC 10 (at 20 mA).
Voltage level:	CC 10 active	the voltages on the signal and control lines of the CC 10 are between –12 V and 0 V (referred to the CC 10 ground).
	CC 10 passive	the no-load voltages of the signal and control lines of the driving device must not exceed max. 24 V and the current must be limited to 20 mA.
Plug connector:	25-pole D-SUB	

6.3 Interface for the operating and programming panel BPF 10/BPF 10 E

The BPF 10 is connected to plug contact **X32** BPF.

The pin assignment is shown in Chapter 3 "Operating and programming panel".

7. DIGITAL INTERFACE

The digital interface of the CC10.3 control system generally occupies 4 bytes of inputs and 4 bytes of outputs in the extended field of control systems CL300, CL400 or CL500.

The interface assignment is designed so that the same interface can be used for synchronous and asynchronous control. With asynchronous control, only signals for the 2nd and 3rd axes are not present (designated by in the overview).

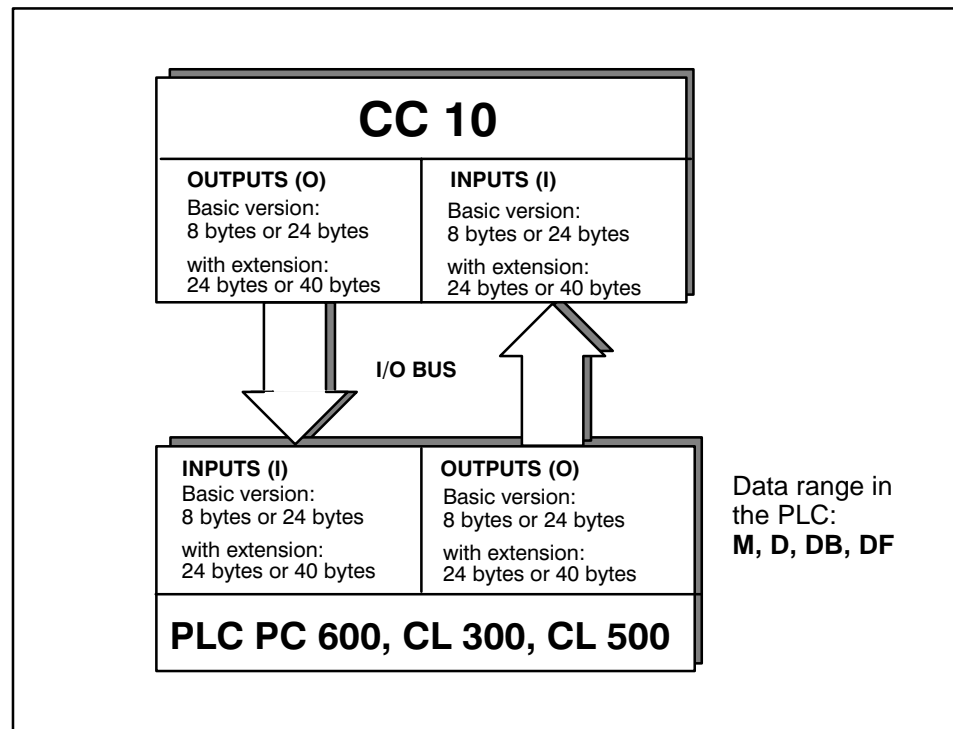

Fig. 7.1

With 3 x 1 asynchronous axis, however, the control system will occupy a total of 24 bytes for inputs and 24 bytes for outputs.

Additional 16 bytes for I/O are required per device for evaluation of the expanded interface functions. In the maximum configuration, the CC 10 thus requires 40 bytes for I/O.

A number of interface signals are not yet used and therefore designated as "reserve".

These signals are reserved for future expansion stages.



CAUTION

7.1

After the control has been switched on, or during the initialisation phase of the CC10, the statuses of the interface signals are not yet defined. The interface signals have defined statuses only once the CC10 is "operative", i.e. when the "Ready" contact on plug X10 is closed (green LED is on).

7.1 CC 10 Interface structure

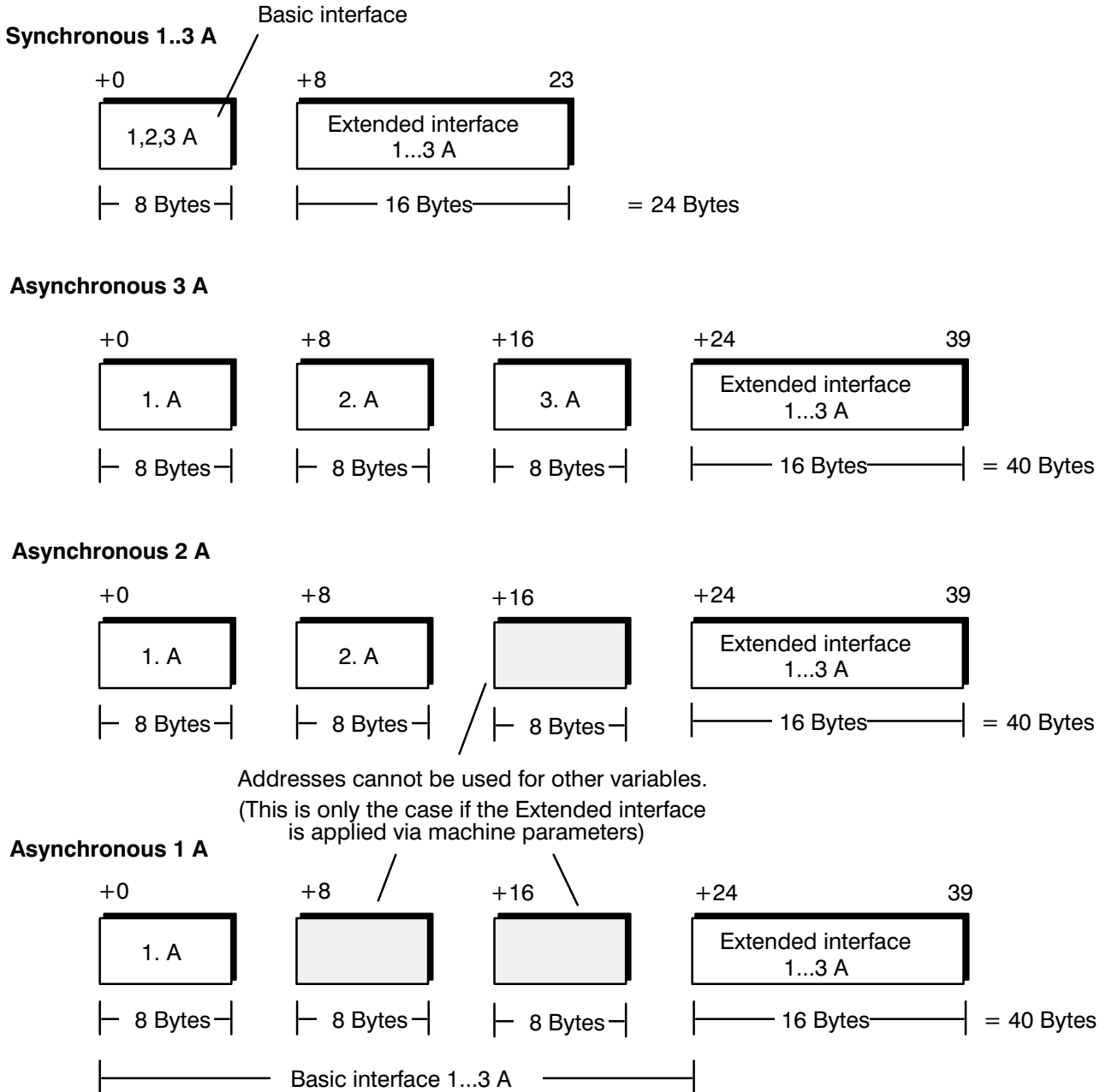

Fig. 7.2



CAUTION

7.2

1. As long as only 1 axis is applied, we recommend defining the P0030 parameter to "SYNCHRONOUS". In this case, 16 bytes less of inputs/outputs are required as with "ASYNCHRONOUS" axes.
(see also machine parameter description)

2. With asynchronous operation with an extended interface, 40 bytes of standard interface data must generally be transmitted, even if only 1 or 2 axes are applied.

7.2 Communication of CC10 with the CC10LOAD module

The CC10 LOAD module executes the data transfer between CC10.3 and the PLC. It is called up immediately after the CC10 user program.

The CC10 LOAD module is provided on a separate disc (order no. **077282**).

The CC10 LOAD module provides two functions:

- Changing interface signals with the PLC
- Changing required data with the PLC

7.2.1 Parameters of the CC10LOAD module:

System Parameters

P0	W	Data module for communication
P1	W	START input (0: No transfer, 2: Activate transfer)
P2	W	Central/local operation
P3	W	Module address of the CC10.3 (acc.to DIP switch) with localized configuration: BM address
P4	W	Bus master FIFO number (only with localized configuration)
P5	W	FIFO depth (only with localized configuration)
P6	W	Bit 0: Data transfer to PLC running Bit 10: CC10.3 is ready to communicate

Base parameters (PLC interface)

P7	W	Offset address of the CC10.3 (M, D, DP, DF) digital interface * (with data words the corresponding data module must already be when the CC10 LOAD module is called up).
P8	W	Length of the digital interface (in bytes) (dependent on configuration acc. to MPP: K8, K16, K24, K40)

Extended parameters (required data for CC10.3)

P9	W	Required data DM number (0 ...255)
P10	W	Start address in required data DM in P8 (K800H ... K97FH)
P11	W	Required data length (in bytes) 0: no required data (entry in multiples of 2)

Extended parameters (required data for PLC)

P12	W	Required data DM number (0 ...255)
P13	W	Start address in required data DM in P11 (K800H ... K97FH)
P14	W	Required data length (in bytes) (return value: 0 – 128)

* Entry as indirect address e.g. for M0: K100H or &M0

Only data exchange of the interface signals with the PLC will be dealt with hereafter. You will find a description of the *required data* function in the description of Remote Control.

7.2.2 Exchanging interface signals with PLC

- The CC10 occupies 4 bytes of EI/EO area at the I/O bus. Data exchange with the PLC takes place via these addresses.
- Memory space must be made available (according to the selected configuration; see fig 7.2) in the PLC for the interface signals. Markers, data modules, data buffers or data field areas can be defined as memory areas.



When using a data module, it must be opened by the time it is called up.

The input interface and output interface of the CC10.3 are always positioned at the start and end of the memory area respectively.

- The number of bytes transferred depends on the configuration selected in the machine parameter (see fig. 7.2).

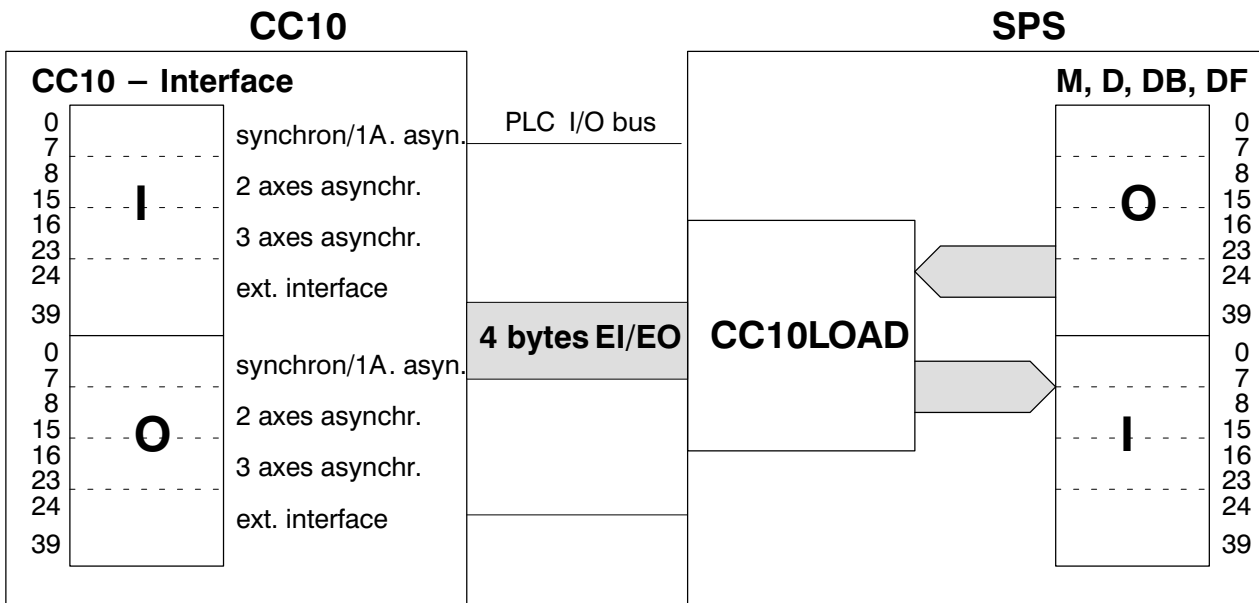

Fig. 7.3

In synchronous mode, the CC10.3 / PLC interface occupies 8 bytes of input area and 8 bytes of output area. A diagram area is defined for this in operands M, D, DB or DF. This area is used to depict firstly the CC10 inputs, and the CC10 outputs directly afterwards. The PLC interface can be extended in machine parameter P0042 by 16 bytes of input area and 16 bytes of output area for additional functions (see fig. 7.2).

Note!

Only one area of 16 bytes I/O is available per CC10.3 regardless of whether 1 x 3 axes (synchronous mode) or 3 x 1 axes (asynchronous mode) is applied.

Three examples for digital interface storage in the PLC:

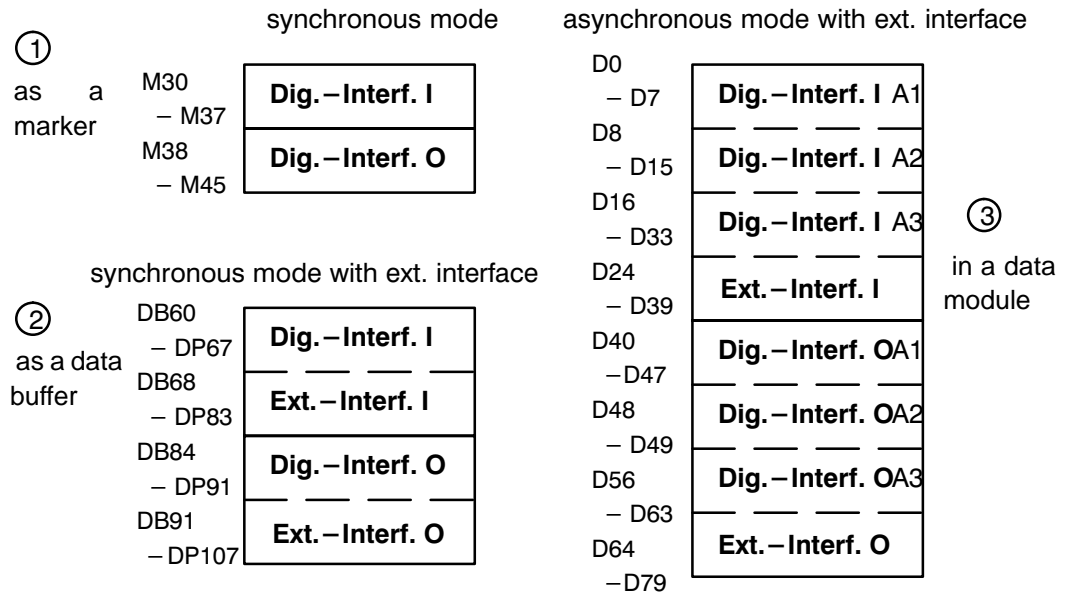

CAUTION!



When a CC10.2 is changed for a CC10.3, existing PLC programs cannot be accepted without changes.



When areas D, DB or DF are being used, bit-wise access to the interface signals is not possible. Bit signals must be requested via an arithmetic register.

Example for CL400, CL500:

Request interface signals:

CM	DM5	;activate data module
L	D0,A	;load data section 0
U	A.3	;request bit 3
.		
=	M5.7	

Set interface signal:

L	D40,B	;load data section 0
U	E2.5	
.		
=OM	B.3	;set bit 3 in register
T	B,D40	

7.3 Digital interface basis

7.3.1 Inputs basis interface

Bit Byte	7	6	5	4	3	2	1	0	
10.	Multiple input strobe	Acknowledge for multiple output	Restart	–	–	–	–	$\overline{\text{STOP}}$	
11.	Basic setting	Set current value	Edit inhibit	Start	Transfer allow	Operating mode coded 4 2 1			
12.	Feed allow Achse 3 <input type="checkbox"/>	Drive on axis 3 <input type="checkbox"/>	Reference point switch axis 2 <input type="checkbox"/>	Feed allow Achse 1 <input type="checkbox"/>	Drive on axis 2 <input type="checkbox"/>	Reference point switch axis 1 <input type="checkbox"/>	Feed allow Achse 1 <input type="checkbox"/>	Drive on axis 1	
13.	–	Optional STOP	Auto restart	User inputs 1 – 4 4 3 2				1	Reference point switch axis 3 <input type="checkbox"/>
14.	Feed in % 4 2		1	Axis select. axis 3 <input type="checkbox"/>	Axis select. axis 2 <input type="checkbox"/>	Axis select. axis 1 <input type="checkbox"/>	Manual –	Manual +	
15.	Multiple input address 8 4 2 1				–	–	Conditional jump	Operating mode input 1:PLC/0:BPF	
16.	Multiple input data (BCD coded) 80 40 20 10 8 4 2 1								
17.	8000	4000	2000	1000	800	400	200	100	

7.3.2 Outputs basis interface

Bit Byte	7	6	5	4	3	2	1	0
00.	Acknowledge for multiple input	Multiple output strobe	–	–	–	–	–	–
01.	Basic setting	In position axis 3 <input type="checkbox"/>	In position axis 2 <input type="checkbox"/>	In position axis 1	Program active	Operating mode coded 4 2 1		
02.	User outputs 1 – 4 4 3 2 1			Software limit switch active	Reference pt. approached axis 3 <input type="checkbox"/>	Reference pt. approached axis 2 <input type="checkbox"/>	Reference pt. approached axis 1	
03.	Multiple outputs address 8 4 2 1				–	Actual value set axis 3 <input type="checkbox"/>	Actual value set axis 2 <input type="checkbox"/>	Actual value set axis 1
04.	Multiple outputs Data (BCD coded) 80 40 20 10 8 4 2 1							
05.	8000	4000	2000	1000	800	400	200	100
06.	BPF connected	ONLINE PLC	NC ready	–	–	–	Program selected	–
07.	Error – / status code 64 32 16 8 4 2 1							Error status general

These signals are not present in asynchronous mode.

7.4 Digital Interface Extension

7.4.1 Overview CC10 inputs (PLC---> CC10)



The start address of the extended interface varies according to the operating mode (synchronous/asynchronous).

Bit Byte	7	6	5	4	3	2	1	0
I8.	Setpoint value axis 1							
	2^7	2^6	2^5	2^4	2^3	2^2	2^1	2^0
I9.	2^{15}	2^{14}	2^{13}	2^{12}	2^{11}	2^{10}	2^9	2^8
I10.	2^{23}	2^{22}	2^{21}	2^{20}	2^{19}	2^{18}	2^{17}	2^{16}
I11.	Sign 0: positive 1: negative	Feed code				1. axis <input type="checkbox"/> setpoint entry inactive	–	2^{24}
I12.	Setpoint value axis 2							
	2^7	2^6	2^5	2^4	2^3	2^2	2^1	2^0
I13.	2^{15}	2^{14}	2^{13}	2^{12}	2^{11}	2^{10}	2^9	2^8
I14.	2^{23}	2^{22}	2^{21}	2^{20}	2^{19}	2^{18}	2^{17}	2^{16}
I15.	Sign 0: positive 1: negative	Feed code				2. axis <input type="checkbox"/> setpoint entry inactive	–	2^{24}
I16.	Setpoint value axis 3							
	2^7	2^6	2^5	2^4	2^3	2^2	2^1	2^0
I17.	2^{15}	2^{14}	2^{13}	2^{12}	2^{11}	2^{10}	2^9	2^8
I18.	2^{23}	2^{22}	2^{21}	2^{20}	2^{19}	2^{18}	2^{17}	2^{16}
I19.	Sign 0: positive 1: negative	Feed code				3. axis <input type="checkbox"/> setpoint entry inactive	–	2^{24}
I20.	Required data input Strobe	Ackn.ledge for required data output	–	–	Actual value display	Setpoint display	0: G91 1: G90	Set position per interface (PLC) MDI
I21.	User inputs							
	12	11	10	9	8	7	6	5
I22.	–	–	–	–	–	–	–	–
I23.	–	–	–	–	–	–	–	–

These signals are not present in asynchronous mode.

7.4.2 Overview CC10 outputs (CC10---> PLC)



The outputs of the extended interface are located behind the outputs of the standard interface. The start address of the extended interface varies according to the operating mode (synchronous/asynchronous).

Bit Byte	7	6	5	4	3	2	1	0
O8.	Display axis 1							
	2^7	2^6	2^5	2^4	2^3	2^2	2^1	2^0
O9.	(Setpoint or actual value)							
	2^{15}	2^{14}	2^{13}	2^{12}	2^{11}	2^{10}	2^9	2^8
O10.	2^{23}	2^{22}	2^{21}	2^{20}	2^{19}	2^{18}	2^{17}	2^{16}
O11.	Sign 0: positive 1: negative	Act. value display axis 1	Nom. value display axis 1	-	-	-	-	2^{24}
O12.	Display axis 2							
	2^7	2^6	2^5	2^4	2^3	2^2	2^1	2^0
O13.	(Setpoint or actual value)							
	2^{15}	2^{14}	2^{13}	2^{12}	2^{11}	2^{10}	2^9	2^8
O14.	2^{23}	2^{22}	2^{21}	2^{20}	2^{19}	2^{18}	2^{17}	2^{16}
O15.	Sign 0: positive 1: negative	Act. value display axis 2	Nom. value display axis 2	-	-	-	-	2^{24}
O16.	Display axis 3							
	2^7	2^6	2^5	2^4	2^3	2^2	2^1	2^0
O17.	(Setpoint or actual value)							
	2^{15}	2^{14}	2^{13}	2^{12}	2^{11}	2^{10}	2^9	2^8
O18.	2^{23}	2^{22}	2^{21}	2^{20}	2^{19}	2^{18}	2^{17}	2^{16}
O19.	Sign 0: positive 1: negative	Act. value display axis 3	Nom. value display axis 3	-	-	-	-	2^{24}
O20.	Required data output Strobe	Ackn.ledge for required data input	-	-	-	-	-	-
O21.	User outputs							
	12	11	10	9	8	7	6	5
O22.	-	-	-	-	-	-	-	-
O23.	-	-	-	-	-	-	-	-

These signals are not present in asynchronous mode

7.5 Signal descriptions

7.5.1 General

The extended field start address for the I/O area of the CC10 is set with a DIP switch on the CC10 module.

The sequence of the individual signals within the digital interface is defined in the operating system and cannot be changed.

Where in the following the terms input signal and output signals are used, it is in the sense of PLC/CC10.3 communication which has already been described.

Example:

Concept: 3 axes, asynchronous, with extended interface

The PLC interface has been applied on the PLC side from marker 10.

The input **I0.0** then corresponds to the marker address **M10.0** and the output **O0.0** to the marker address **M50.0**.

7.5.2 Notes on the signal description

- The input and output signals and their description are referred to the CNC interface. In the diagrams, (I) stands for an input of the CC 10 and (O) for an output.
- Auxiliary signals are used in the diagrams to facilitate understanding. These are marked accordingly

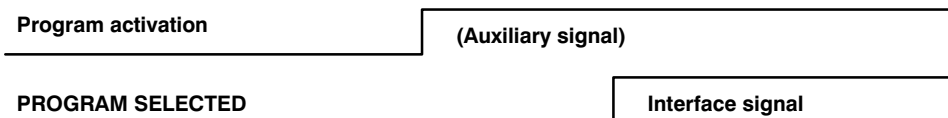

7.5.3 Description of the basic input signals (PLC → CC 10)

STOP

I 0.0

The STOP signal affects all traversing movements and has priority over START (in all modes).

In automatic mode, for example, STOP does not stop the program if no traversing movements have been programmed in the block in which the STOP is triggered. Those blocks which only contain auxiliary functions, for example, are executed accordingly.

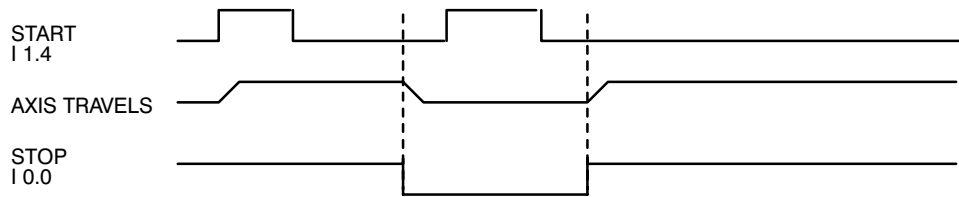

Function in the control system:

- 1 signal A "hold condition" is not present. Axes can be started and traversed. Any axis movement interrupted by STOP is continued (without repeated START).
- 0 signal Axis movement is stopped, i.e. the axes are braked in accordance with the set acceleration curve. **No** axis movement can be started with START.

INPOS is not sent following STOP in all modes (except for manual and approach reference point) as long as a residual displacement remains. In the case of INCREMENTAL JOG in manual mode, STOP interrupts the traversing movement and INPOS is output.

RESTART

I 0.5

The RESTART signal causes the CC 10 to run up, comparable with the state immediately after switching on or after pressing the RESET key on the front panel.

Function in the control system:

- | | |
|----------|---|
| 1 signal | The control system executes the initialization phase, the "Ready" contact is open.
Any errors which can be cancelled only by Reset, e.g. servo-errors, are reset.
The signal should not be applied for more than approx. 300 ms. If this time is exceeded, an additional initialization phase is started immediately as soon as the run-up or restart has been completed. |
| 0 signal | Not operative |

**ACKNOWLEDGE MULTIPLE OUTPUT
MULTIPLE OUTPUT STROBE**

I 0.6
O 0.7

A lead and lag time which can be defined via machine parameters is started in conjunction with the MULTIPLE OUTPUT STROBE signal. Data transfer from the CC 10 to the PLC via MULTIPLE DATA OUTPUT can be acknowledged by the PLC. This ensures that both the strobe signal and the lag time can be interrupted and the CC 10 continues execution of the part program.

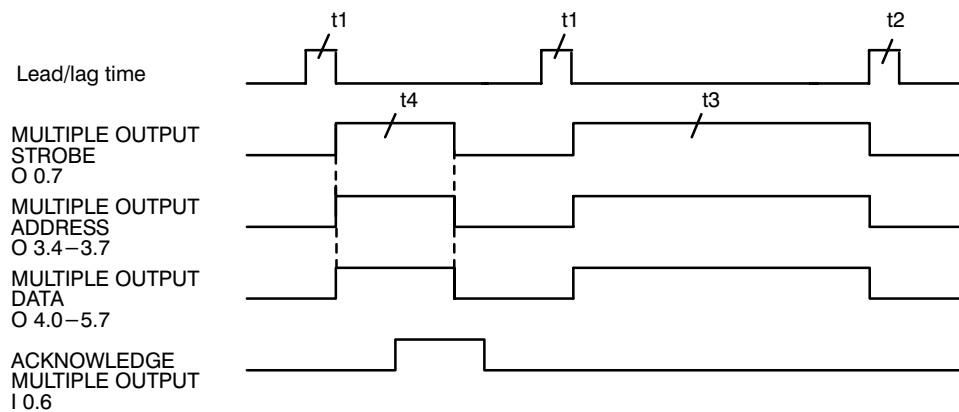

Function in the control system

- $t_1 = t_2$ Lead and lag time
- $t_3 =$ Signal duration (machine parameter) for MULTIPLE OUTPUT STROBE.
- $t_4 = t_3$ In this case, however, shortened by the signal ACKNOWLEDGE MULTIPLE OUTPUT.

MULTIPLE OUTPUT ADDRESS and MULTIPLE OUTPUT DATA are valid with the positive edge of MULTIPLE OUTPUT STROBE. MULTIPLE OUTPUT STROBE, MULTIPLE OUTPUT ADDRESS and MULTIPLE OUTPUT DATA are reset by the CC 10 with the positive edge of ACKNOWLEDGE MULTIPLE OUTPUT.

If the MULTIPLE OUTPUT STROBE signal is low, ACKNOWLEDGE MULTIPLE OUTPUT must be reset by the PLC.

MULTIPLE INPUT STROBE
ACKNOWLEDGE MULTIPLE INPUT

I 0.7
O 0.6

Data transfer between PLC → CC 10 is accomplished via the signals MULTIPLE INPUT STROBE, MULTIPLE INPUT ADDRESS and MULTIPLE INPUT DATA.

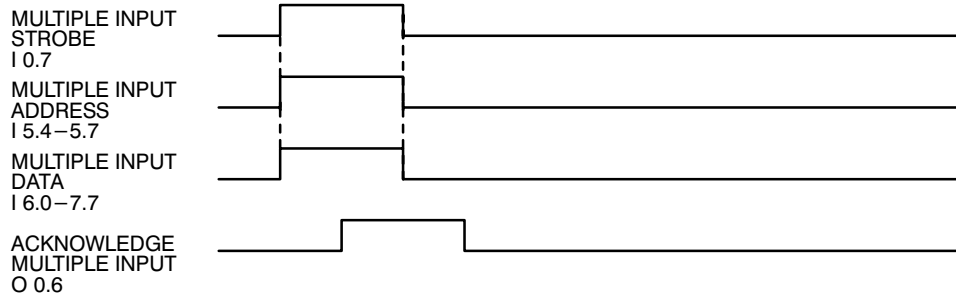

Function in the control system

MULTIPLE INPUT ADDRESS and MULTIPLE INPUT DATA must be defined and set by the PLC when the positive edge of MULTIPLE INPUT STROBE is received.

ACKNOWLEDGE MULTIPLE INPUT is set if the CC 10 has accepted the data.

The signal MULTIPLE INPUT STROBE is then reset by the PLC.

Finally, ACKNOWLEDGE MULTIPLE INPUT is reset by the CC 10.

OPERATING MODES

I 1.0 – I 1.2

The control system has a number of operating modes:

OPERATING MODE (BA)	LOGIC STATE				
	BYTE 1	BIT	2	1	0
NO OPERATING MODE			0	0	0
MANUAL			0	0	1
APPROACH REFERENCE POINT			0	1	0
SEMI-AUTOMATIC			0	1	1
AUTOMATIC			1	0	0
* MANUAL INPUT			1	0	1
TEST			1	1	0
RESERVED			1	1	1

* external setpoint presetting possible in manual input mode

It is only possible to change from AUTOMATIC and SEMI-AUTOMATIC to APPROACH REFERENCE POINT and MANUAL following a STOP or when IN POSITION is signalled.

If an operating mode change takes place while the axes are moving, this leads to abortion of the running program.

The changeover between AUTOMATIC and SEMI-AUTOMATIC can be made at any time; however, the block in progress is completed first.

The operating modes MANUAL and APPROACH REFERENCE POINT are mutually exclusive.

If the operating modes are to be preset via the PLC sequence program (I 5.0 "Mode preset PLC/BPF" = 1), the corresponding bit combination (see above) must be present at inputs I 1.0, I 1.1, I 1.2.

In the event of a mode change during the braking phase (down slope) of the axis, the control panel (BPF 10) is not polled and the display is not refreshed.

Function in the control system

- **NO MODE**
The active mode is cancelled.
- **MANUAL**
The axes can be incrementally or continuously traversed in manual mode. The speed depends on the bit combination specified at the interface (refer to the description I 4.5–I 4.7).
- **APPROACH REFERENCE POINT**
The axes approach the reference point in accordance with the activated inputs I 4.2–4.4. The direction of approach is specified via parameters. The signal SET ACTUAL VALUE must possess the state logical 0. The speed corresponds to the speed defined in machine parameter P0301 and can be influenced by means of the inputs I 4.5–4.7.

Example for axis 1 (basic principle)

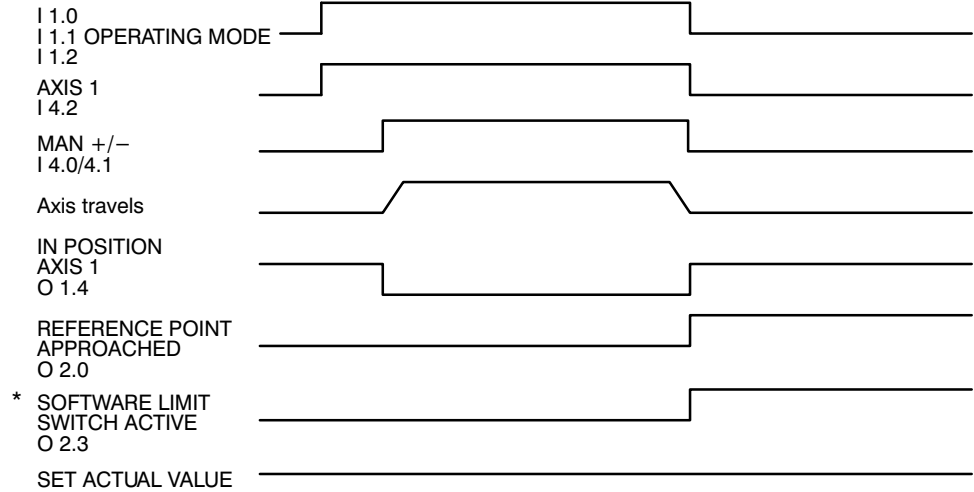

*** Note:**

The software limit switches become active when all axes have traveled to the reference point once in synchronous mode. In asynchronous mode, the corresponding axis must be synchronized with the reference point.

Note:

The sequence for "Approach reference point" differs.

1. Approach reference point after switching on the CC 10 or after SET ACTUAL VALUE

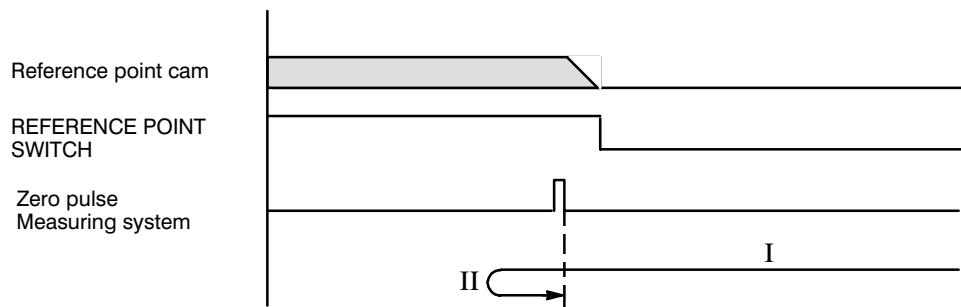

- I The axis moves in the direction defined in machine parameter P 340.
- II After detection of the zero pulse, the axis moves through the follow-up phase, reverses direction and synchronizes with the positive edge of the zero pulse.

Note:

If the reference point is approached after SET ACTUAL VALUE, the axis must be located at a mechanical position where it is possible to find the reference point switch (pay attention to reference point approach direction).

2. Approach reference point after having already synchronized with the zero pulse once.

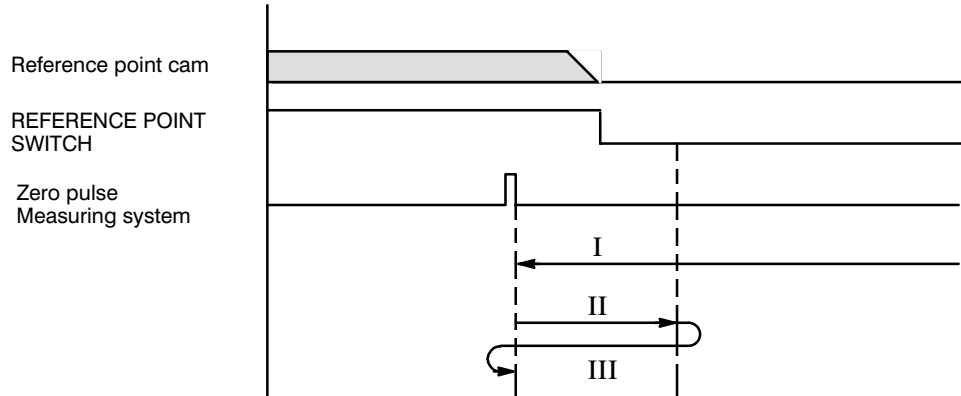

- I The axis approaches the numerical position of the reference point at reference point speed (P0301) and remains in this position until the reference point switch is signalled.
- II When the high signal for the reference point switch has been signalled to the CC 10 via the interface, the axis moves away from the reference point cam in the opposite direction.
- III Following the low signal for the reference point switch, the axis reverses direction and synchronizes with the positive edge of the zero pulse.

SEMI-AUTOMATIC

The part program is executed block-by-block by START (precondition: NC READY must be logical 1).

AUTOMATIC

The part program is executed as far as M02 or M30 after START (precondition: NC READY must be logical 1).

MANUAL INPUT

In this mode, a setpoint value can be preset relative to the axis via the "extended interface". (This function can also be realized via the BPF in a subsequent expansion stage.)

TEST

An NC part program is checked for SYNTAX errors.

DATA ENABLE

I 1.3

Data in enable is created in the PLC and influences execution of the part program.

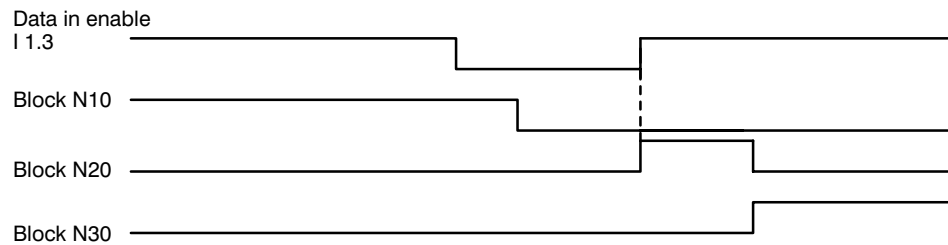

Function in the control system

- 1 signal The enable signal for execution of a new block is present.
- 0 signal The active block is executed. However, the next block is not executed unless DATA IN ENABLE has level 1.

START

I 1.4

Start is effective in modes AUTOMATIC, MANUAL INPUT and SEMI-AUTOMATIC. The positive edge is evaluated internally by the control system.

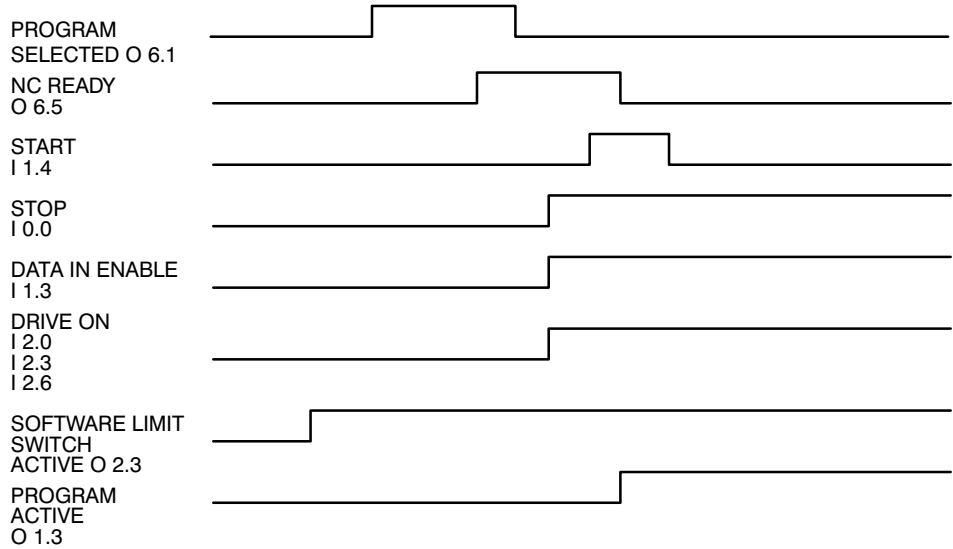

Function in the control system

- 1 signal Depending on the operating mode, the positive edge starts
 - a program
 - an NC block
 - a positioning cycle.
 The 1 signal may be set only if the signal NC ready already possesses logical 1 state.
 In addition, the signals STOP, DRIVE ON, DATA IN ENABLE and SOFTWARE LIMIT SWITCH ACTIVE must also be set.
 The coding for AUTOMATIC, SEMI-AUTOMATIC or MANUAL INPUT must be present at outputs 1.0...1.2,
- 0 signal The negative edge (or logical 0) does not have any effect.

EDIT DISABLE

I 1.5

Function in the control system

- | | |
|----------|---|
| 1 signal | The part programs, zero shifts and length compensations cannot be edited. |
| 0 signal | The part programs, zero shifts and length compensations can be edited. |

SET ACTUAL VALUE

I 1.6

This function can replace the function "Approach reference point" (within the control), but without synchronization with the zero pulse. The operating mode "Approach reference point" must be active. SET ACTUAL VALUE is not active in conjunction with an absolute encoder or revolution-coded rotary encoder (e.g. to E60). Unlike APPROACH REFERENCE POINT, the axis must first traverse a traversing distance \geq reversing backlash for the SET ACTUAL VALUE function. The reversing backlash is offset in the following direction reversal.

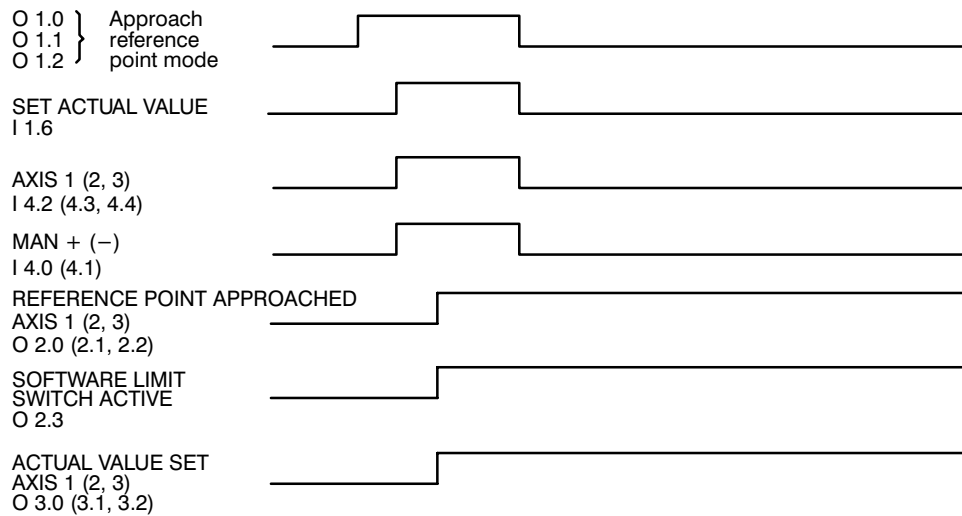

Function in the control system

1 signal The positive edge of MAN+ in conjunction with SET ACTUAL VALUE sets the actual value of the selected axis to the value which is defined as machine parameter P0230 inside the control. The CC 10 issues the axis-specific signal ACTUAL VALUE SET as acknowledgement. In addition, the axis-specific signal REFERENCE POINT APPROACH is set.

The axis-specific signals "ACTUAL VALUE SET" indicate that the corresponding axis has not, however, actually travelled to the reference point, with the result that no synchronization with the zero pulse of the measuring system has taken place either.

The signals "ACTUAL VALUE SET" are reset when the normal reference point approach cycle (I 1.6 = logical 0) is performed.

The signal SOFTWARE LIMIT SWITCH ACTIVE is set when the axes are either synchronized with the zero pulse of the measuring system or SET ACTUAL VALUE is initiated via the PLC sequence program.

If the reference point is approached after SET ACTUAL VALUE, the signal SOFTWARE LIMIT SWITCH ACTIVE is reset until the axis is synchronized with the zero pulse.

0 signal The normal reference point approach cycle is executed (refer to the description of reference point approach).

CAUTION!



The software limit switches are set in conjunction with SET ACTUAL VALUE in the same way as after completion of reference point approach. However, the axis must not be positioned at the zero pulse of the measuring system, but may assume an arbitrary position within the mechanically possible traversing range. This results in an offset of the permitted traversing range with respect to the machine datum.

If the axis is now traversed, there is a risk that the axis will travel against the axis end limit (fixed stop). In order to prevent accidents or damage in conjunction with the function SET ACTUAL VALUE, the installation planner must take suitable precautions.

BASIC SETTING

I 1.7

This function can be triggered via softkey or interface signals.

The positive edge is evaluated internally by the control.

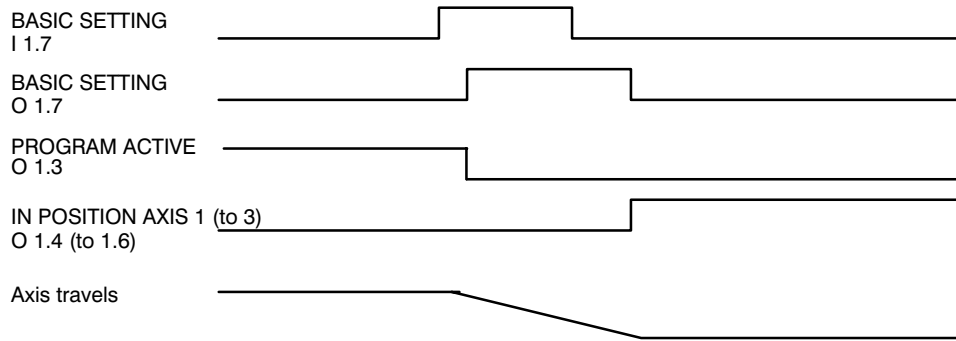

Function in the control system

1 signal The BASIC SETTING signal sets the control system to switch-on status (following reference point approach).

All active data (such as zero shift) are reset. If the axes are in motion, they are guided (slope), braked to "0" and IN POSITION is output.

The operating modes are preserved (in accordance with the bit combinations present at the interface).

0 signal No effect in the CC 10.

DRIVE ON AXIS 1	I 2.0
DRIVE ON AXIS 2	I 2.3
DRIVE ON AXIS 3	I 2.6

The signal DRIVE ON closes the position control loop.

In order to stop the axes or traverse through an external setpoint, the position control loop is opened by setting DRIVE ON to "0". The signal DRIVE ON (axis-specific) must remain set as long as trigger enable is set on the servo-amplifier.

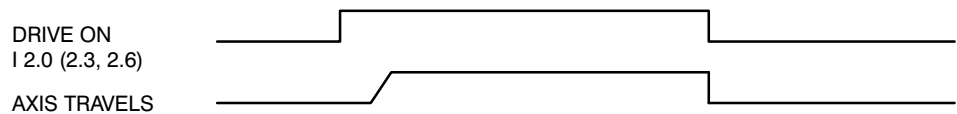

Function in the control system

1 signal The signal DRIVE ON must be "logical 1" if an axis is to be traversed. The signal remains set as long as trigger enable is set on the servo-amplifier. The follow-up monitor (servo-error, interpolator stop) is activated. **All** axes must approach the reference point once after switching in order to be able to execute part programs. The signal DRIVE ON must also be set for all axes in order to be able to approach the reference point.

0 signal The setpoint output is set to "0".

The setpoint is always set equal to the actual value. The axes can also be traversed via an external setpoint. If DRIVE ON is switched to "0" during a traversing movement, the setpoint output is set to "0 V" without slope.

Planning notes

The effect of setting or cancelling DRIVE ON differs, depending on the various operating states.

Example 1:

Synchronous axis operation, automatic mode is active, 3 axes traverse, DRIVE ON cancelled for axis 1 before the latter reaches the programmed setpoint.

Effect: All axes are stopped; the axes do not move IN POSITION if the programmed setpoint positions are not reached.
An error message is output. In order to be able to traverse axes 2 and 3, for example by means of MAN+, "Basic setting" must be input; as a result of the basic setting function, the SETPOINT position is made to correspond to the instantaneous ACTUAL POSITION on the display and all axes move IN POSITION. Axis 1 can be traversed only if DRIVE ON is set for axis.

Example 2:

The CC 10 runs a program in AUTOMATIC mode, DRIVE ON is not set for axis 1, and a block is to be executed in which a traversing movement is programmed for all 3 axes.

Effect: The program is executed as far as the block in which the traversing movement for axis 1 has been programmed. The CC 10 detects that DRIVE ON is missing for the 1st axis and therefore does not execute this block, i.e. no traversing movement is started. Instead, an error message is output. The block is not executed by the CC 10 until DRIVE ON is set for axis 1. A basic setting reset signal has priority, as otherwise too, and interrupts the program.

Example 3:

DRIVE ON for axis 1 is cancelled while axis 1 is IN POSITION (setpoint = actual). DRIVE ON for axis 1 is searched before a traversing movement starts.

Effect: As long as DRIVE ON is set to 0, the machine position is detected and the setpoint value adjusted in line with the actual value. The axis remains IN POSITION, since no setpoint has been preset. The subsequent traversing movement (DRIVE ON set) is performed relative to the instantaneous ACTUAL POSITION.

Example 4:

Handling the signal DRIVE ON. Axis 3 must be clamped during the machining time.

Program example 1:

.	
.	
N100 X02=100 X03=500	
N110 M11	Clamp axis 3, cancel the trigger enable of the servo–amplifier and the signal DRIVE ON for axis 3.
.	
.	
N250 M12	Data in enable cancelled, trigger enable and DRIVE ON set. Data in enable is set again as soon as clamping has been cancelled.
.	
.	
N260 X03=60	Axis X03 is positioned at 60 mm

Program example 2:

The auxiliary function "M" is output via machine parameters with an internal transfer stop, i.e. before execution of the traversing movement; "M" must be acknowledged by the PLC sequence program.

.	
.	
N100 X02=100 X03=500	
N110 M11	Clamp axis 3, cancel the trigger enable for the servo–amplifier and the signal DRIVE ON for axis 3.
.	
.	
N250 M12 X03=60	Set trigger enable and DRIVE ON; the auxiliary function M12 is acknowledged when the clamp is released and axis X03 moves to position 60 mm.

Example 5:

The axis must be traversed by the amount of an external setpoint during the machining time. In this case, the procedure is the same as described for example 4. The positions (machine position and actual position) are detected as long as the signal DRIVE ON is 0 and serve as the reference point for the next programmed traversing movement.

Example 6:

Manual operation
The axis concerned cannot be traversed as long as DRIVE ON has not been set. An error message is output if MAN +/- is actuated; the axis remains IN POSITION.

FEED ENABLE AXIS 1	I 2.1
FEED ENABLE AXIS 2	I 2.4
FEED ENABLE AXIS 3	I 2.7

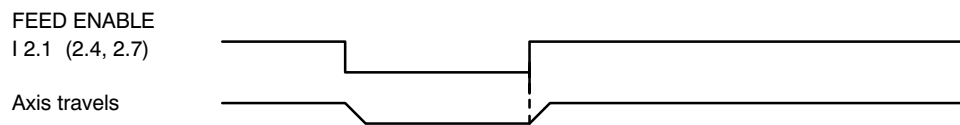

Function of the control system

1 signal FEED ENABLE is available once per axis.

If a number of axes are programmed in one block, FEED ENABLE must be set for every axis involved in the movement. If a FEED ENABLE is cancelled, all programmed axes stop.

0 signal The movement is stopped in accordance with the slope function.

If a new block is started, the axis does not move until FEED ENABLE is present; however, the signal IN POSITION already assumes the state "logical 0".

REFERENCE POINT SWITCH AXIS 1	I 2.2
REFERENCE POINT SWITCH AXIS 2	I 2.5
REFERENCE POINT SWITCH AXIS 3	I 3.0

The REFERENCE POINT SWITCH identifies the range in which the axes are synchronized with the "markers" of the incremental measuring system.

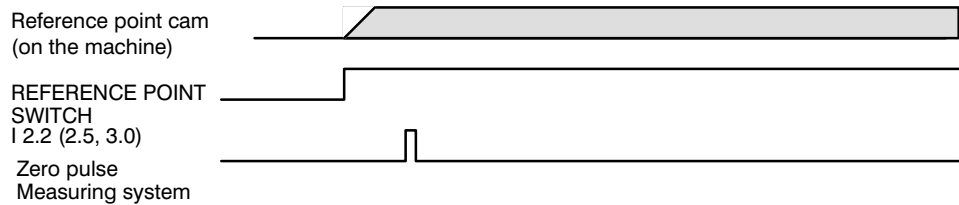

Function in the control system

- 1 signal** The axis is synchronized with the zero pulse of the measuring system in conjunction with the operating mode APPROACH REFERENCE POINT (refer to the description of OPERATING MODES). The zero pulse is always approached from the same edge (as a function of machine parameter P340).
- 0 signal** No effect in the CC 10 i.e. the axis cannot be synchronized with the zero pulse.

USER INPUT 1	I 3.1
USER INPUT 2	I 3.2
USER INPUT 3	I 3.3
USER INPUT 4	I 3.4

The user inputs can be interlinked in combination with the function keys F1–F12 (on the BPF 10).

The effect and significance of the function keys are described under P500 in the machine parameter manual.

AUTO RESTART	I 3.5
---------------------	--------------

Function in the control system

- | | |
|----------|---|
| 1 signal | Causes the program to start automatically without resetting the START signal at the end of the program in AUTOMATIC mode.
The signal must have "1" level before the active program is ended. |
| 0 signal | The part program is not automatically restarted. |

OPTIONAL STOP**I 3.6****Function in the control system**

- | | |
|----------|---|
| 1 signal | If "M01" is programmed in the part program, the automatically executed program will be interrupted after this block. M01 is still output to the interface. Processing can be continued by a renewed START signal. |
| 0 signal | Program execution is not interrupted by "M01" in the part program. |

MAN +	I 4.0
MAN –	I 4.1
AXIS 1	I 4.2
AXIS 2	I 4.3
AXIS 3	I 4.4

The signals MAN +/- and AXIS x are functionally-related and are effective in MANUAL and APPROACH REFERENCE POINT modes.

If the axes are defined as "asynchronous" axes (i.e. 3 x 1 axis), it is unnecessary to select "axis 1".

Movements are initiated directly via MAN + or MAN –.

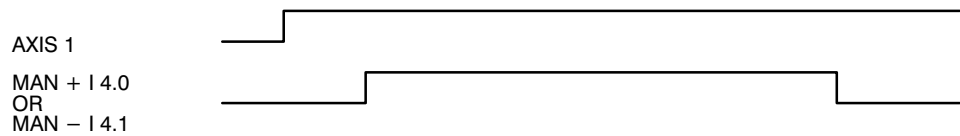

Function in the control system

MANUAL

The signal AXIS x selects the axis to be traversed.

The direction of traversing is determined by MAN +/-.

All three axes can be traversed simultaneously.

APPROACH REFERENCE POINT

The signal AXIS x selects the axis to be traversed.

The axis is traversed (or SET ACTUAL VALUE is executed) by means of MAN + or MAN –.

The reference point can be approached by all 3 axes simultaneously.

FEED %

I 4.5, 4.6, 4.7

FEED % is active in all operating modes and is statically evaluated internally in the control system.

FEED %	LOGIC STATE				
	BYTE 4	BIT	7	6	5
NO FEED, NO INCREMENTAL JOG			0	0	0
1 INCREMENT			0	0	1
10 INCREMENTS			0	1	0
100 INCREMENTS			0	1	1
FREELY SELECTABLE VIA MACHINE PARAMETERS			1	0	0
25 %			1	0	1
50 %			1	1	0
100 %			1	1	1

The present incremental displacement is effective in MANUAL (and TEACH-IN) mode.

The speed for preset incremental displacement is 25 % of the maximum speed.

PRESET OPERATING MODE PLC/BPF

I 5.0

The operating modes (refer to the description of the input signals I 1.0 – I 1.2) can be preset by the PLC sequence program or via the control panel BPF 10.

Function in the control system

- 1 signal The operating mode is preset via the input signals I 1.0, E 1.1, I 1.2. It is not possible to change the operating mode via the BPF 10 (the softkey "MODE" for operating mode presetting is not present).
- 0 signal The operating mode is preset via the corresponding softkey on the BPF 10. The operating mode cannot be changed via the input signals I 1.0, I 1.1, I 1.2.

CONDITIONAL JUMP

I 5.1

The signal CONDITIONAL JUMP results in a conditional jump in conjunction with G function G23 (refer to the programming instructions, description G23).

The function G23 is programmed in conjunction with an L address in the part program. The L address defines the jump destination; the jump destination is always a block number (N...).

The jump to the block number defined under L is performed if the signal I 5.1 CONDITIONAL JUMP possesses the state "Logical 1".

The interface signal I 5.1 is already polled internally by the NC during block preparation.

A change in the state of the interface signal I 5.1 between block preparation (max. 5 blocks) and block execution is no longer taken into account.

If the signal change nevertheless has to be taken into account, block preparation must be stopped by programming the command WAIT.

MULTIPLE INPUT ADDRESS
MULTIPLE INPUT DATA

I 5.4 – I 5.7
I 6.0 – I 7.7

Various functions are realized via the multiple input.

MULTIPLE INPUT ADDRESS	BYTE 5 LOGIC STATE			
	BIT 7	6	5	4
NO FUNCTIONS	0	0	0	0
EXT. PROGRAM SELECTION	0	0	1	0
EXT. BLOCK SELECTION	0	0	1	1
INTERFACE MODE	0	1	0	0
	0	1	0	1
	0	1	1	0
	0	1	1	1
	1	0	0	0
	1	0	0	1
	1	0	1	0
	1	0	1	1
	1	1	0	0
	1	1	0	1
	1	1	1	0
	1	1	1	1

The corresponding bit combinations for the functions

- External program selection
- External block selection
- Interface mode

are defined at the multiple input address.

It is necessary to set

- the program number or
- the block number or
- the interface mode

at the multiple input data in BCD code in parallel to setting of these bit combinations.

EXTERNAL PROGRAM SELECTION

I 5.4 – I 5.7

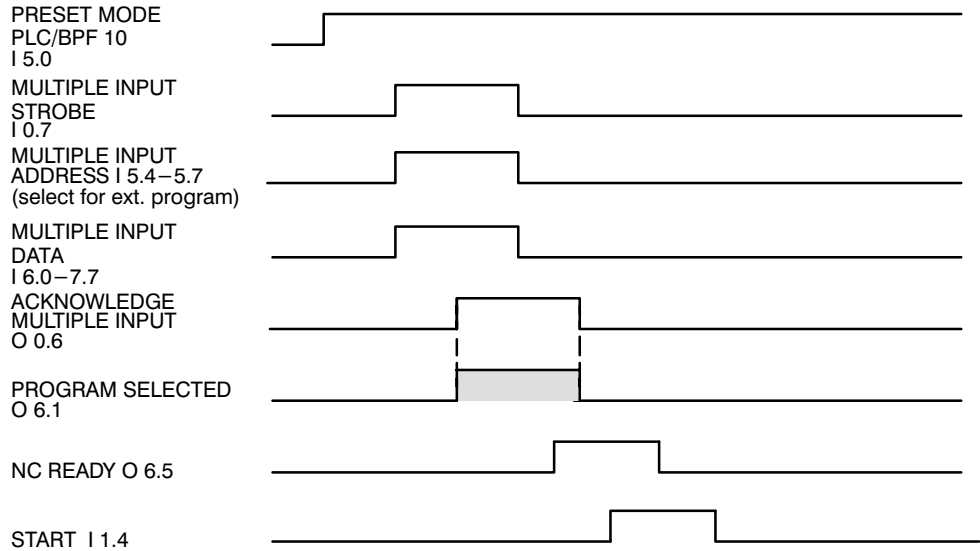

Function in the control system

EXTERNAL PROGRAM SELECTION is performed in "handshake mode".

EXTERNAL PROGRAM SELECTION is activated in the CC 10 by MULTIPLE INPUT STROBE (in conjunction with MULTIPLE INPUT ADDRESS and MULTIPLE INPUT DATA).

The operating modes "Automatic" or "Semi-automatic" must be present for output signals O 1.0 – 1.2.

The signal ACKNOWLEDGE MULTIPLE INPUT is output to the PLC after internal evaluation in the control system.

The signal "PROGRAM SELECTED" is output at the same time, provided that the selected program has been activated internally in the control system.

The program can be started via the signal START (refer to the description of the interface signal START) after selecting a program.

If the movement is interrupted via the signal STOP, a new program can be selected although the axis is not IN POSITION.

The new program is executed following the START signal.

EXTERNAL BLOCK SELECTION

I 5.4 – I 5.7

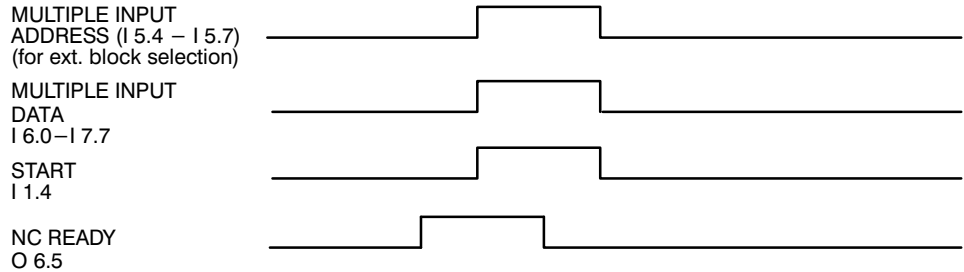

Function in the control system

The program can be started with START after selection of a program and when NC READY possesses the state "Logical 1" (refer to description of external program selection).

Execution of the program starts with the first programmed NC block. Execution can also start with any other NC block defined in the part program in conjunction with the function EXTERNAL BLOCK SELECTION.

If the code for EXTERNAL BLOCK SELECTION is present at the MULTIPLE INPUT ADDRESS in conjunction with START, the part program is started with the block number (N...) which is present in BCD code at MULTIPLE INPUT DATA.

In order to accelerate the time sequence with respect to EXTERNAL BLOCK SELECTION, the handshake procedure has been consciously dispensed with (MULTIPLE INPUT STROBE, ACKNOWLEDGE MULTIPLE INPUT).

MULTIPLE INPUT ADDRESS, MULTIPLE INPUT DATA and START are reset when the signal NC READY has the logical state "0".

It is possible to specify a new block number with every START in single-block mode (SEMI-automatic). In this context, attention must be paid to the fact that previously activated modal functions, e.g. G90/G91, G63/G66, remain active.

INTERFACE MODE

I 5.4 – I 5.7

Data can be read in/out via different interfaces. Selection is possible via the BPF 10 (refer to operating instructions) or via the interface. Switch-over can take place at any time via the interface. The user must therefore ensure that switch-over to a different interface takes place only when no data transfer is active. Should the interface be switched nevertheless, transfer errors may occur.

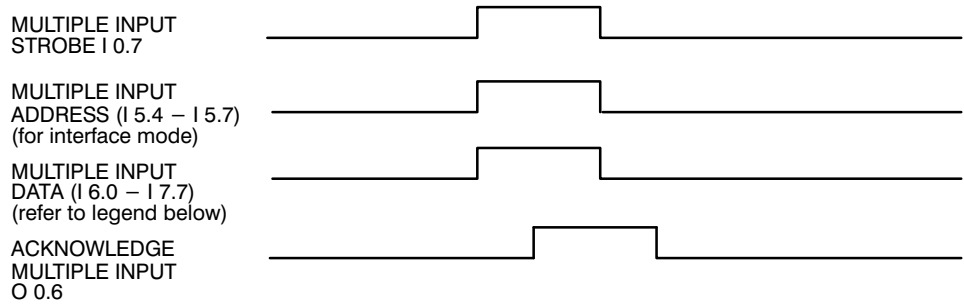

Function in the control system

MULTIPLE INPUT ADDRESS and MULTIPLE INPUT DATA are evaluated by the CC 10 with MULTIPLE INPUT STROBE.

The input 5.6 must possess the state "Logical 1" for the functions INTERFACE MODE; the inputs I 5.4, 5.5, 5.7 must possess the state "Logical 0".

The following BCD codes must be present at MULTIPLE INPUT DATA.

Interface	BCD-Code
OFFLINE V24	0
ONLINE V24	1
ONLINE PLC	2

Note:

You will find concrete interface descriptions in the *Operating and Programming Manual*, chapters *Operation* and *Remote*.

7.5.4 Description of the basic output signals (CC 10 → PLC)

ACKNOWLEDGE MULTIPLE INPUT **O 0.6**

Refer to the description for MULTIPLE INPUT STROBE I 0.7

MULTIPLE OUTPUT STROBE **O 0.7**

Refer to the description for ACKNOWLEDGE MULTIPLE OUTPUT I 0.6

OPERATING MODES **O 1.0 – O 1.2**

OPERATING MODE	LOGIC STATE				
	BYTE 1	BIT	2	1	0
NO OPERATING MODE			0	0	0
MANUAL (SETUP)			0	0	1
APPROACH REFERENCE POINT			0	1	0
SEMI-AUTOMATIC			0	1	1
AUTOMATIC			1	0	0
MANUAL INPUT			1	0	1
TEST			1	1	0
Reserved			1	1	1

Function in the control system

The operating mode is present statically at the outputs O 1.0, O 1.1, O 1.2 when the preset mode has been activated in the CC 10.

The functions are described in the description of the interface signal OPERATING MODES I 1.0 – 1.2.

PROGRAM ACTIVE

O 1.3

(Also refer to the description of signals START I 1.4 and BASIC SETTING I 1.7)

Function in the control system

- | | |
|----------|---|
| 1 signal | The signal PROGRAM ACTIVE is output as long as a block is active and no STOP (in conjunction with a programmed traversing movement), M00, M01, M02 or M30 is present. |
| 0 signal | No block is executed in the CC 10, STOP (in conjunction with a programmed traversing movement) is present or M00/M01 or M02/M30 was programmed. |

IN POSITION AXIS 1	O 1.4
IN POSITION AXIS 2	O 1.5
IN POSITION AXIS 3	O 1.6

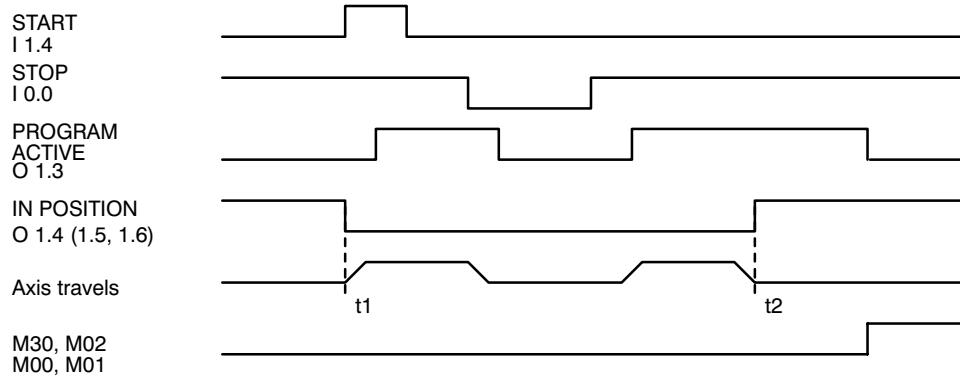

- t1 The axis is no longer in the IN POSITION range defined by the machine parameters.
- t2 The block (program) has been fully executed and the axis is in the IN POSITION range.

Function in the control system

- 1 signal The signal IN POSITION is output when the programmed displacement has been reached and/or the axis is within the IN POSITION range.
The IN POSITION range is defined as a machine parameter.
- 0 signal The axis is not in the IN POSITION range or has not yet reached the programmed end.

BASIC SETTING	O 1.7
----------------------	--------------

Refer to the signal description BASIC SETTING I 1.7

REFERENCE POINT APPROACH AXIS 1	O 2.0
REFERENCE POINT APPROACH AXIS 2	O 2.1
REFERENCE POINT APPROACH AXIS 3	O 2.2

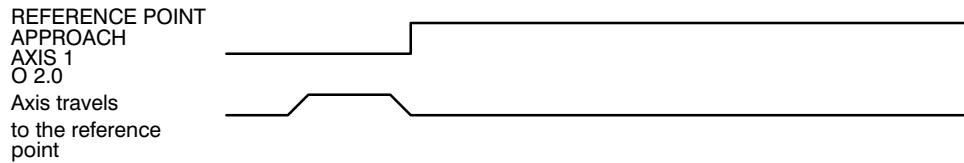

Function in the control system

1 signal The signal REFERENCE POINT APPROACH AXIS 1 is set when the axis travels to the reference point and is synchronized with the zero pulse.

REFERENCE POINT APPROACH is set in conjunction with G74 when the reference point position has been reached (without synchronization with the zero pulse).

0 signal The axis has not yet reached the reference point or has moved away from it as a result of manual or programmed traversing.

SOFTWARE LIMIT SWITCH ACTIVE**O 2.3****Function in the control system**

1 signal SOFTWARE LIMIT SWITCH ACTIVE is present as a static signal when all axes (as defined in machine parameter P020) have travelled to the reference point once or SET ACTUAL VALUE has been executed after switching on.

0 signal If one axis of 2 or 3 axes has not travelled to the reference point after switching on, then SOFTWARE LIMIT SWITCH ACTIVE is not set.

If ACTUAL VALUE SET was activated previously (refer to signal I 1.6 SET ACTUAL VALUE), then the signal SOFTWARE LIMIT SWITCH ACTIVE is reset with a subsequent APPROACH REFERENCE POINT until the axis is synchronized with the zero pulse.

Note:

Execution in automatic, semi-automatic or manual input mode is possible only if the signal SOFTWARE LIMIT SWITCH ACTIVE is logical 1.

SOFTWARE LIMIT SWITCH ACTIVE is set immediately after signalling that the CC 10 is ready for operation in conjunction with absolute measuring systems (no incremental measuring system).

USER OUTPUT 1	O 2.4
USER OUTPUT 2	O 2.5
USER OUTPUT 3	O 2.6
USER OUTPUT 4	O 2.7

The user outputs can be interlinked in conjunction with the function keys F1 – F12 (on the BPF 10).

The effect and significance of the function keys are described under P500 in the machine parameter manual.

ACTUAL VALUE SET AXIS 1	O 3.0
ACTUAL VALUE SET AXIS 2	O 3.1
ACTUAL VALUE SET AXIS 3	O 3.2

Refer to signal description "SET ACTUAL VALUE" I 1.6.

MULTIPLE OUTPUT ADDRESS
MULTIPLE OUTPUT DATA

O 3.4 – 3.7
O 4.0 – 5.7

Various functions are realized via the MULTIPLE OUTPUT.

MULTIPLE OUTPUT ADDRESS	BYTE 3			
	BIT 7	6	5	4
	0	0	0	0
	0	0	0	1
	0	0	1	0
	0	0	1	1
	0	1	0	0
	0	1	0	1
	0	1	1	0
	0	1	1	1
	1	0	0	0
	1	0	0	1
	1	0	1	0
	1	0	1	1
	1	1	0	0
1ST AUXILIARY FUNCTION	1	1	0	1
2ND AUXILIARY FUNCTION	1	1	1	0
3RD AUXILIARY FUNCTION	1	1	1	1

Function in the control system

Refer to the description and diagram for the signal ACKNOWLEDGEMENT FOR OUTPUT I 0.6.

The output order for the auxiliary function is defined in machine parameter P400.

PROGRAM SELECTED

O 6.1

Refer to signal EXTERNAL PROGRAM SELECTION I 5.4 – I 5.7

NC READY

O 6.5

Refer to the description of PRESET SETPOINT AXIS 1 or START for a signal diagram.

Function in the control system

1 signal The signal NC READY is sent from the CC 10 to the PLC sequence program in modes AUTOMATIC and SEMI-AUTOMATIC when a program has been selected and the CC 10 is ready to process a START signal (after every block in SEMI-AUTOMATIC MODE, after M00, M01, M02, M30, after the basic setting reset and after selection of a program).

NC READY is output in MANUAL INPUT mode when the CC 10 is ready to travel to a setpoint with START.

0 signal The CC 10 is not ready to process the START signal.

Important:

After an operating mode change via the PLC interface, the signal NC ready must be polled only when the operating mode defined by the PLC has been activated in the CC 10. The mode becomes active when the mode defined by the PLC is acknowledged by the CC 10 in the output signals O 1.0 – 1.2. It must also be noted that the signal NC READY is polled only if the signals

– I 0.7 MULTIPLE INPUT STROBE

– O 0.7 MULTIPLE OUTPUT STROBE

are logical 0.

ON–LINE PLC**O 6.6**

The signal ON–LINE PLC possesses the state logical 1 if data transfer, e.g. for part programs, via the PLC is preselected.
If the V.24/20 mA interface is preselected for data transfer, the signal ON–LINE PLC possesses the state logical 0.

BPF CONNECTED**O 6.7****Function in the control system**

- | | |
|----------|---|
| 1 signal | The control panel BPF 10(E) is connected. |
| 0 signal | The control panel BPF 10(E) is not connected. |

**GENERAL ERROR
ERROR CODE****O 7.0**
O 7.1 – O 7.7

GENERAL ERROR is always present whenever an ERROR CODE is present.

Errors can be cleared by the basic setting function, a reset or elimination of the cause (depending on their type). Those errors marked can only be cancelled by pressing the RESET key via the input signal RESTART or by switching the CC 10 off and then on again.

The ERROR CODE is binary-coded.

You will find a list of error codes, their causes and suggested remedies in the Overview (chapter 8) at the end of this manual.

7.5.5 Description of the input signals, expansion stage (PLC → CC 10)

PRESET SETPOINT, 1ST AXIS

I 8.0 – I 11.7

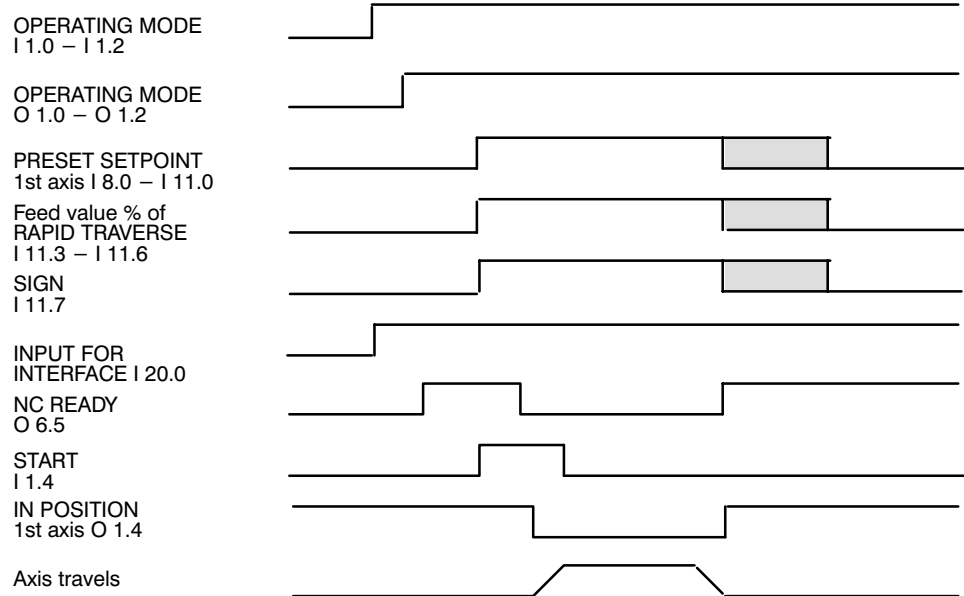

- The operating modes are signalled to the CC 10 via the interface signals 1.0, 1.1 and 1.2.
- The expanded interface makes it possible to specify a position relative to each axis together with the speed (in increments of 10 % of the rapid traverse speed) for each interface.
- The setpoint is preset in binary form in bits 8.0 to 11.0.
- The bit 11.7 is used for the sign (logical "0" – positive value).
- The signal "INPUT FOR INTERFACE" I 20.0 must be set when selecting the operating mode.
- The signal NC READY indicates that the control system expects a preset setpoint and that the signal START can be set.
- The traverse command is accepted by the interface with the START signal and the movement is started. Precondition: setpoints and feed values $\neq 0$ %.
- If the operating modes MANUAL INPUT and INPUT FOR INTERFACE are still present after reaching the preset position, NC READY is output again.
- The signal NC READY is set to "0" after a change of operating mode.

1ST PRESET SETPOINT INACTIVE, 1ST AXIS

I 11.2

Function in the control system

The setpoint for the 1st axis at the input I 8.0 – I 11.7 can be preset in absolute (G90, I 20.1 = 1) or incremental (G91, E 20.1 = 0) form.

The input I20.1 applies to all axes; if G91 is preselected, for example, the CC 10 interprets the preset setpoint incrementally for the axes 1, 2 and 3. After START, all axes would then incrementally traverse the displacement distance preset at the inputs I 8.0 – I 11.7, I 12.0 – I 12.7 and I 16.0 – I 19.7. However, the preset setpoint for the 1st axis is ignored if the signal 11.2 PRESET SETPOINT INACTIVE, 1st AXIS, is set to logical 1.

Hinweis:

The preset setpoint for the 1st axis is preset only for axes in synchronous operation.

FEED %

I 11.3 – I 11.6

F-VALUE % OF RAPID TRAVERSE SPEED	BYTE 11		LOGIC STATE		
	BIT	6	5	4	3
100 %		0	0	0	0
90 %		0	0	0	1
80 %		0	0	1	0
70 %		0	0	1	1
60 %		0	1	0	0
50 %		0	1	0	1
40 %		0	1	1	0
30 %		0	1	1	1
20 %		1	0	0	0
10 %		1	0	0	1
5 %		1	0	1	0
4 %		1	0	1	1
3 %		1	1	0	0
2 %		1	1	0	1
1 %		1	1	1	0
0 %		1	1	1	1

Function in the control system

A speed (F-value) must be entered in 10 % increments of the rapid traverse speed for the preset position in bits I 11.3 – I 11.6.

A feed rate can be preset for each individual axis in the case of asynchronous axes. The same feed rate must be specified at inputs I 11.3 – I 11.6 for synchronous axes. The feed in % (refer to input signals I 4.5 – 4.7) has priority over the F-value.

The feed values applied to the extended PLC interface at I11.3 to I11.6 have an additive function for the feed values applied at I4.5 to I4.7 (base PLC interface).

PRESET SETPOINT, 2ND AXIS **I 12.0 – 15.7**

Refer to the description of PRESET SETPOINT, AXIS 1

PRESET SETPOINT INACTIVE, 2ND AXIS **I 15.2**

Refer to the description of PRESET SETPOINT INACTIVE, AXIS 1

PRESET SETPOINT, 3RD AXIS **I 16.0 – 19.7**

Refer to the description of PRESET SETPOINT, AXIS 1

PRESET SETPOINT INACTIVE, 3RD AXIS **I 19.2**

Refer to the description of PRESET SETPOINT INACTIVE, 1ST AXIS

PRESET SETPOINT POSITION **I 20.0**

Function in the control system

- 1 signal Position input (in MANUAL INPUT mode) takes place via the interface.
- 0 signal Position input (in MANUAL INPUT mode) takes place via the BPF 10 (future expansion stage).

G90/G91 **I 20.1**

Function in the control system

- 1 signal If preset via the interface, the positions are traversed in absolute G90 values.
- 0 signal If preset via the interface, the positions are traversed in incremental G91 values.

SETPOINT DISPLAY **I 20.2**

Function in the control system

- 1 signal The setpoint positions of the axes are output to outputs 8.0 – 19.7.
- 0 signal The setpoint positions are not output.

ACTUAL VALUE DISPLAY

I 20.3

Function in the control system

1 signal The actual positions of the axes are output at outputs 8.0 – 19.7.

0 signal The actual positions are not output.

ACKNOWLEDGE DATA CHANNEL OUTPUT

I 20.6

Refer to the description DATA CHANNEL OUTPUT STROBE

**REQUIRED DATA INPUT STROBE
ACKNOWLEDGEMENT FOR REQUIRED DATA INPUT**

**I 20.7
O 20.6**

A maximum of 128 bytes of data can be transferred from the PLC to the CC10 via the REQUIRED DATA CHANNEL INPUT function of the CC10LOAD module. Transfer take place in ASCII code. The data in the PLC are generally stored in data modules. The DM number, the start address of the data area and the length of the data are made available to the CC10LOAD module in parameter form.

The type of data and their significance are described in the section on "Remote Control".

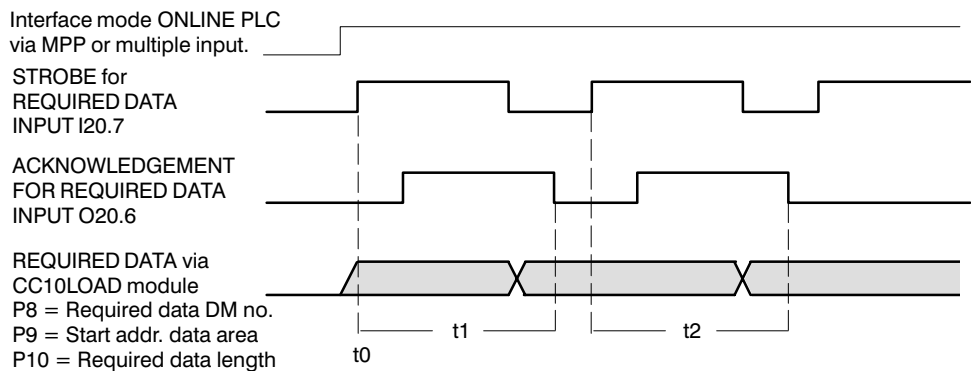

Example:

A part program is to be transferred via the REQUIRED DATA INPUT, triggered by the PLC. The header of the part program is defined as follows:

(DFS,P.....etc.)

A maximum of 128 ASCII characters can be transferred from the PLC to the CC10 per transfer operation. DATA CHANNEL INPUT STROBE is set to logical 1 at instant t0.

By this point, the data to be transferred should be present in the designated data module. The data must be preceded with a DFS header (see below). The data block is accepted into the CC10 with the 0/1 edge of the REQUIRED DATA INPUT STROBE INPUT I20.7.

The CC10 acknowledges acceptance with the ACKNOWLEDGEMENT FOR REQUIRED DATA INPUT O20.6 signal. The REQUIRED DATA INPUT STROBE signal must be reset with this signal in the PLC program. At the same time, new data can be supplied at the REQUIRED DATA INPUT.

After the CC10.3 has reset the ACKNOWLEDGEMENT FOR REQUIRED DATA INPUT signal, the next data transfer operation can commence.

The next (max.) 128 characters are then transferred during the period t2.

ASCII	Hexadec. code
(28
D	44
F	46
S	53

7.5.6 Description of the output signals, expansion stage (CC 10 → PLC)

DISPLAY 1ST AXIS

O 8.0 – 11.7

If the interface is expanded via MPP, the setpoint or actual value for axes 1–3 is output via the outputs O 8.0 – 11.7 as a function of the signals 11.5 and 11.6.

OPERATING MODE	BYTE 11	LOGIC STATE	
	BIT	6	5
NO EFFECT		0	0
ACTUAL VALUE DISPLAY		1	0
SETPOINT DISPLAY		0	1

Internal NC output is refreshed approx. every 80 ms; output for the PLC sequence program then takes place approx. every 80 ms + 1 x PLC cycle time.

DISPLAY 2ND AXIS

O 12.0 – 15.7

Refer to the description for DISPLAY AXIS 1

DISPLAY 3RD AXIS

O 16.0 – 19.7

Refer to the description for DISPLAY AXIS 1

ACKNOWLEDGEMENT FOR REQUIRED DATA INPUT

O 20.6

Refer to the description DATA CHANNEL INPUT STROBE

**DATA CHANNEL OUTPUT STROBE
ACKNOWLEDGE DATA CHANNEL OUTPUT**

O 20.7
I 20.6

A maximum of 128 bytes of data can be transferred from the PLC to the CC10 via the REQUIRED DATA CHANNEL INPUT function of the CC10LOAD module. Transfer take place in ASCII code. The data in the PLC are generally stored in data modules. The DM number, the start address of the data area and the length of the data are made available to the CC10LOAD module in parameter form.

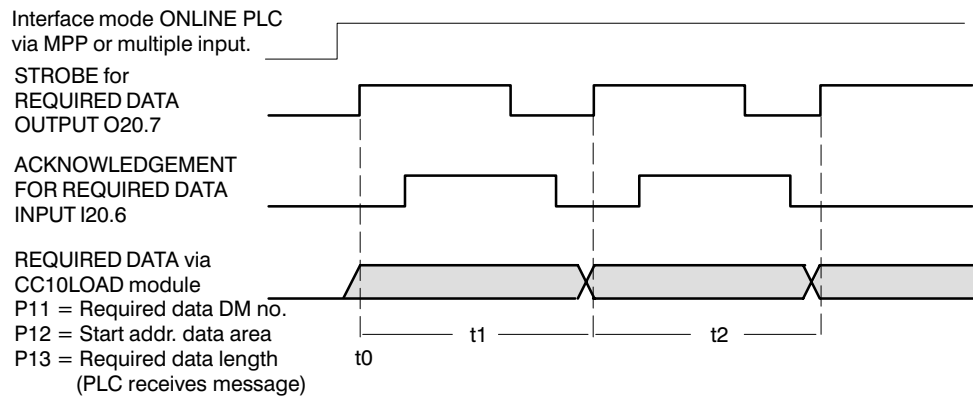

Example:

A part program has been transferred from the PLC to the CC10 beforehand via the required data function.

The CC10 now acknowledges this transfer with the following message:

<STX> (NCS,FTR OK) <ETX>

A maximum of 128 ASCII characters can be transferred from the CC10 to the PLC per transfer operation. The CC10 sets the REQUIRED DATA OUTPUT STROBE O20.7 to logical 1 at instant t0.

At the same instant, the CC10 writes the check-back signal into the data area of the designated data module.

The PLC program acknowledges acceptance of the check-back signal with the ACKNOWLEDGEMENT FOR REQUIRED DATA OUTPUT I20.6 signal. The DATA OUTPUT STROBE signal is then reset by the CC10.

The PLC program must likewise be rest by the ACKNOWLEDGEMENT FOR REQUIRED DATA OUTPUT.

The next data transfer operation can then commence.

ASCII	Hexadec. code
(28
N	4E
C	43
S	53

8. Error codes

The following list contains all error codes which can potentially be displayed on the PLC interface (O7.1 – O7.7) and BPF (FBL INFO). They are accompanied by possible causes and concrete advice to help the user remedy the error.

After remedying an error, those error numbers marked trigger a restart (run-up) in the controller as well.

CC 10 Error number	Display (Text)	Significance	Possible causes	Remedy
F003	RANGE?	Programmed traversing range too large	Displacement > 360° on rotary axes	Enter new displacement
<input type="checkbox"/> F004	MPP.ERROR	Machine parameter error	<p>Format for parameter P300 > 3.3</p> <p>Maximum traversing speed = 24 m/min. (with 0.001 mm resolution) → 400.000 < P200 [pulses/mm] • P300 [mm/s]</p> <p>Rotary axis is operated with revolution-coded, incremental encoder</p> <p>On rotary axis: value for reference position (P230) > 360°</p> <p>On linear axis: value for reference position (P230) outside traversing range</p> <p>Number of axes (P020) > 3</p> <p>On revolution-coded, incremental encoder: P220 – P210 > traversing range of the encoder</p> <p>Range monitoring P210 or P220 > possible traversing distance</p>	Adapt parameter

CC 10 Error number	Display (Text)	Significance	Possible causes	Remedy
F005	ILLEGAL CHAR.	Illegal character	Wrong order when entering characters, e.g. a letter instead of digit after N On rotary axis: displacement in revolutions, preset value > 32.767 revolutions	Edit program addresses correctly Enter new value
F006	PROGR IS ACTIVE	Program is selected and activated	Attempt to edit in the active program	Cancel program by means of "Basic setting" function and reselect for editing
F007	LIMIT SWITCH	Limit switch approached	A traversing range outside the software limit switches is detected in a program Displacement lies outside the traversing range	Correct program correspondingly
<input type="checkbox"/> F008	SERVO FAULT 1 A	Servo-fault on the 1st axis	The setpoint of the position controller to the speed controller exceeds the permitted range (sign reversal) Positive feedback of the system, servo-output defective, servo-amplifier does not react correctly to setpoint input of the CC 10	Check the motor feeder cable
<input type="checkbox"/> F009	SERVO FAULT 2 A	Servo-fault on the 2nd axis		Check the measuring system
<input type="checkbox"/> F010	SERVO FAULT 3 A	Servo-fault on the 3rd axis		Check the servo-amplifier
F011	INTER. STOP 1 A	Interpolator stop 1st axis	Excessive overtravel, speed too high, mechanical system does not move easily	Check the speed, mechanical system, parameters or loop gain factor, adjust servo-amplifier
F012	INTER. STOP 2 A	Interpolator stop 2nd axis		
F013	INTER. STOP 3 A	Interpolator stop 3rd axis		
F014	ILLEGAL FORMAT	Illegal format	Entered range of values too large, e.g. F 7.0 or illegal function, e.g. G90 for revolution-programmed rotary axis or G74 for revolution-coded incremental encoder	Edit, enter correct value
F015	WRONG ACCELERAT.	Illegal acceleration	Acceleration too high for preset speed (programmed value plus override)	Edit, enter correct value

CC 10 Error number	Display (Text)	Significance	Possible causes	Remedy
F016	OUTPUT FAULT	Output fault	Problems with output on the V.24/20 mA interface, e.g. wrong device, wrong baud rate, wrong handshake signals, parity error	Initialize interface correctly
<input type="checkbox"/> F017	E2P. PRGR. ERROR	E2PROM programming error	E2PROM cannot be written, is defective	Replace E2PROM
F018	E2P. WRITE PROT.	E2PROM write-protected	WRITE-Protect switch set to "ON" position	Set WRITE-Protect switch to "Off"
F019	E2P OVERFLOW	E2PROM overflow	E2PROM is full	Delete programs not required
F020	PROGR. NOT POSS.	as for 17		
<input type="checkbox"/> F021	NO MARKER 1 A	No marker 1 A	No marker after one encoder revolution	Check the measuring system feeder cable, connector
<input type="checkbox"/> F025	NO MARKER 2 A	No marker 2 A	Wire discontinuity	Check the ground and screen connections
<input type="checkbox"/> F029	NO MARKER 3 A	No marker 3 A	Defective encoder	
<input type="checkbox"/> F022	POS. ERROR 1 A	Position error 1st axis	Encoder pulses/encoder revolution do not agree with the parameter "Number of encoder lines"	
<input type="checkbox"/> F026	POS. ERROR 2 A	Position error 2nd axis	Wrong parameter	Check the ground and screen connections
<input type="checkbox"/> F030	POS. ERROR 3 A	Position error 3rd axis	Wire discontinuity	
			Encoder defective	
<input type="checkbox"/> F023	MS. ERROR 1 A	Measuring system error 1st axis	Encoder defective	Check the measuring system
<input type="checkbox"/> F027	MS. ERROR 2 A	Measuring system error 2nd axis	Cable discontinuity	
<input type="checkbox"/> F031	MS. ERROR 3 A	Measuring system error 3rd axis	Short-circuit	

CC 10 Error number	Display (Text)	Significance	Possible causes	Remedy
<input type="checkbox"/> F024	2EDGE/CLOCK 1 A	2 edge/system CLOCK	2 active counting edges within one clock period. (Counting direction not clearly detectable)	Check the measuring system Check the ground and screen connections
<input type="checkbox"/> F028	2EDGE/CLOCK 2 A		2 active counting edges within one clock period. (Counting direction not clearly detectable)	Check the measuring system Check the ground and screen connections
<input type="checkbox"/> F032	2EDGE/CLOCK 3 A			Check the measuring system Check the ground and screen connections
F033	E2. COR. TAB. LOST	Length compensation table in E2PROM lost	E2PROM defective Empty E2PROMs have been installed	Enter new length compensation tables
F034	ZERO SHIFT LOST	Zero shift table in E2PROM lost	Empty E2PROMs have been installed	Enter new zero shift table
F035	NO STORAGE	No free storage space is available for part programs	Program too long, e.g. 1 kByte is still free, but program has a length of 2 kBytes	Delete programs not required
F036	I/O TIME OUT	Input/output timeout	No characters are received within 5 seconds after starting read-in	Start the data input device accordingly
F037	FAULT DFS HEAD	Fault in DFS head	Syntax error in DFS head	Edit, define DFS head as described in the programming instructions
F038*	ABS. SYNC. ERR.	Synchronization CC 10 – absolute encoder not possible	Data communication absolute encoder – CC 10 not taking place correctly	Possibly wrong parameters
F039*	ABS. WRITE ERR.	Not possible to write to the dual-port RAM on the absolute encoder module in the CC 10	RAM or busy FF on the absolute encoder defective	Replace control system

* Occurs only in conjunction with absolute encoder

CC 10 Error number	Display (Text)	Significance	Possible causes	Remedy
F040*	ABS. RAM ERROR	Dual-port RAM error on the absolute encoder module in the CC 10	RAM on the absolute encoder module defective	Replace control system
F042*	ANS. ENC. ERR.	General error on absolute encoder module	Watchdog of the absolute encoder has responded	Replace control system
F044	EDIT DISABLE	Disables editing	IF signal edit disable present	Cancel IF signal
F045	NO PROGRAM	Program to be output does not exist	Wrong program No. selected Memory empty	Select correct program No.
<input type="checkbox"/> F046**	POS. COD. MAR 1 A	Position of the coded marker 1st axis	No coded marker has been received within the defined traversing range	Check the parameter "Revolutions"
<input type="checkbox"/> F047**	POS. COD. MAR 2 A	Position of the coded marker 2nd axis	Wrong parameter	Check the encoder wiring
<input type="checkbox"/> F048**	POS COD. MAR 3 A	Position of the coded marker 3rd axis	Wrong wiring of the encoder Wire discontinuity Encoder defective	Check the measuring system
<input type="checkbox"/> F049**	POS. CYC. MAR 1 A	Position of the cyclic marker 1st axis	No cyclic marker has been received within a defined traversing range	Check the measuring system wiring
<input type="checkbox"/> F050**	POS. CYC. MAR 2 A	Position of the cyclic marker 2nd axis	Wire discontinuity Encoder defective	Check the ground and screen connections
<input type="checkbox"/> F051**	POS. CYC. MAR 3 A	Position of the cyclic marker 3rd axis		
<input type="checkbox"/> F052**	ENC. FAULT 1 A	Encoder fault 1st axis	The position of the axis does not correspond with the absolute position of the coded marker Encoder defective Encoder connection incorrectly wired	Check the wiring and the measuring system Replace the measuring system
<input type="checkbox"/> F053**	ENC. FAULT 2 A	Encoder fault 2nd axis		
<input type="checkbox"/> F054**	ENC. FAULT 3 A	Encoder fault 3rd axis		

* Occurs only in conjunction with absolute encoder
** Occurs only in conjunction with revolution-coded rotary encoder

CC 10 Error number	Display (Text)	Significance	Possible causes	Remedy
<input type="checkbox"/> F055**	NOMZ-PARAM. 1 A	The number of revolutions encoded in the coded marker is higher than the programmed number of revolutions	Parameter incorrectly programmed	Check the parameter "Revolutions"
<input type="checkbox"/> F056**	NOMZ-PARAM. 2 A			
<input type="checkbox"/> F057**	NOMZ-PARAM. 3 A			
F058	NO REF. POINT	No reference point approached	The reference point has not yet been approached in one or more axes. Program cannot be started.	Travel the axes to the reference point
F059	ILLEGAL FEED	Feed illegal	Preset feed lies outside the machine parameter value	Program the feed correspondingly
F060	ILLEGAL PARAM.	Parameter illegal	Acceleration value does not correspond to the speed (division by 0)	Reduce acceleration or increase speed
F061	DATA LOCKED	Interlock between read-in of the compensation tables and editing of the compensation table	Editing and reading-in simultaneously	Either only editing or only read-in
F062	LOFFSET IGNORED	Length compensation is not active	Call of length compensation Hxx for rotary axes	Delete the call in the part program
F063	Z-SHIFT IGNORED	Zero shift not active	Call of zero shift for rotary axes if the position data are preset in revolutions	Delete the call in the part program
F064	ILLEGAL H-GROUP	Compensation group illegal	Selected H group > 24 or > 72	Modify the part program accordingly
<input type="checkbox"/> F065	PLC STOPPED	PLC has executed an I/O cycle for longer than 2 s	Hardware PLC defective, cycle time of PLC program too long	Ensure that the I/O cycle occurs within 2 s
** Occurs only in conjunction with revolution-coded rotary encoder				

CC 10 Error number	Display (Text)	Significance	Possible causes	Remedy
F066	NO MPP DATA	NO MPP data	MPP data do not correspond to the internal checksum	Enter new MPP data
<input type="checkbox"/> F067*	CABLE FAULT 1 A	Cable discontinuity on the absolute encoder	Mechanical damage	Test the encoder cable and replace if necessary
<input type="checkbox"/> F068*	CABLE FAULT 2 A			
<input type="checkbox"/> F069*	CABLE FAULT 3 A			
<input type="checkbox"/> F070*	POWERFAIL 1 A	Encoder power failure	Malfunctions in encoder power supply	Test the encoder cable and replace if necessary
<input type="checkbox"/> F071*	POWERFAIL 2 A			
<input type="checkbox"/> F072*	POWERFAIL 3 A			
<input type="checkbox"/> F073*	DATA ERROR 1 A	The encoder supplies different values after two data requests	Malfunctions on the encoder line or defective encoder	Check the encoder and encoder line
<input type="checkbox"/> F074*	DATA ERROR 2 A			
<input type="checkbox"/> F075*	DATA ERROR 3 A			
F076	DRIVE OFF 1 A	Traverse command pending but signal "Drive on" not present	PLC program or input signal itself	Check signal "Drive on" in the PLC program
F077	DRIVE OFF 2 A			
F078	DRIVE OFF 3 A			
<input type="checkbox"/> F079	KV FACTOR? 1 A	The numerical value of the KV (loop gain) factor does not correspond to the other drive data. This may lead to division by zero internally	Wrong value for KV (loop gain)	Correct KV, Vmax or pulse factor, see formula: $K_{VL} = \frac{3096481 \text{ [pulses]} \cdot K_v \left[\frac{\text{m}}{\text{min} \cdot \text{mm}} \right]}{P200 \left[\frac{\text{pulses}}{\text{mm}} \right] \cdot P300 \left[\frac{\text{m}}{\text{min}} \right]}$
<input type="checkbox"/> F080	KV FACTOR? 2 A			
<input type="checkbox"/> F081	KV FACTOR? 3 A			
				Values must be entered without units. Errors F79...81 indicated if $K_{VL} < 100$
F082	LIMIT SWITCH 1 A	Software end limit switch has been approached	Software limit switch has been approached	Move the axis away in the opposite direction
F083	LIMIT SWITCH 2 A			
F084	LIMIT SWITCH 3 A			

* Occurs only in conjunction with absolute encoder

CC 10 Error number	Display (Text)	Significance	Possible causes	Remedy
F086	SET ERROR	A block number has not been found in definition of a block number for the CC 10	Wrong block preset	Check block preset by PLC
<input type="checkbox"/> F087 <input type="checkbox"/> F088 <input type="checkbox"/> F089	V–ERROR 1 A V–ERROR 2 A V–ERROR 3 A	a) General for all measuring systems Standstill monitoring function has responded, see description in Section 4.4.5 of interface conditions. b) Actual speed on the absolute encoder does not correspond to the required speed	Axis stuck or drive not in control loop (e.g. trigger enable missing) or drive amplifier or axis moving although there is no travel command from the control Encoder defective	Check mechanism and wiring Replace encoder
F090	HARDWARE CONFIG.	The parameter P201 does not agree with the hardware. e.g. P201 defined for absolute encoder, but measuring system input incremental The hardware identification (axis board) is not correct	Parameter P201 not correctly defined Hardware defective	Correct parameter P201 Replace device
F091	E–CODE ERROR	Checksum of ASCII valencies (E–code) incorrect	Data transfer corrupt	Repeat data transfer, check checksum (E–code)
F092 F093 F094	REF. CAM 1 A? REF. CAM 2 A? REF. CAM 3 A?	Applies only as from 2nd approach to reference point. Axis positioned at the reference point position, but the reference point switch is not signalled	Reference point switch or feeder cable defective	Check switch or feeder cable and replace if necessary
** Occurs only in conjunction with absolute encoder				

CC 10 Error number	Display (Text)	Significance	Possible causes	Remedy
F095	ILLEGAL PLANE	Wrong plane selection	The axes defined for G18 or G19 do not exist in the control	Program the correct plane in the part program
F096	ILLEGAL RADIUS	Programmed radius not permitted	The programmed radius is less than half the distance from the start point to the end point	Correct the radius in the part program
F097	ILLEGAL RISE	The pitch of the infeed axis is too large (for interpolation of a helical line)	The travel of the infeed axis must not be greater than the travel on the circular path	Correct the pitch in the part program
F098	ILLEGAL CIRCLE	A full circle has been programmed	The start point and end point are identical	Program two circle segments
F099	PLC CYCLE TIME?	The PLC cycle time is too short	The PLC cycle time must be > 5 ms	Extend the PLC cycle time
F100	ILLEGAL RTC	The servo-loop sampling time is too short	The internal limit values in MPP21 are not observed	Set a longer servo-loop sampling time in MPP21
F101	FAULT MP300	Machine parameter P300 is incorrectly defined	The max. speed is too high	Reduce the max. speed
F102	FAULT MP200	Machine parameter P200 is incorrectly defined	The cut-off frequency for the measuring system input is exceeded	Check parameters P300 and P200
F103	FAULT MP110,201	The selected measuring system is not permitted for the defined axis	A revolution-coded, incremental measuring system is on the rotary axis	Replace the measuring system by a "purely" incremental measuring system and redefine MP201 correspondingly
F104	FAULT MP210,220	The definitions for the software limit switches are incorrect	<ul style="list-style-type: none"> – The reference point is outside the traversing range – The traversing range of the revolution-coded, incremental rotary encoder is exceeded – $P210$ or $P220 \cdot P200 > 2^{31}$ 	Reduce the values for the software limit switches correspondingly

CC 10 Error number	Display (Text)	Significance	Possible causes	Remedy
F105	FAULT MP201	The measuring system selection is not correct	The hardware is not designed for absolute measuring systems	Replace hardware
F106	FAULT MP360–379	The definitions in MP360–379 are not correct	Damping of preset setpoint of one or more stages not correct	Set again in accordance with instructions in MPP description
F107	FAULT MP100, 400	The designations of the auxiliary functions or axes are not correct	The designations of the auxiliary functions and axes overlap or are identical	Change designations
F109	FEP.DEL FAULT	FLASH-EPROM not correctly deleted	FLASH-EPROM defective	Replace hardware
F110	FEP.PRG FAULT	FLASH-EPROM not written in correctly	FLASH-EPROM defective	Replace hardware
F111	PRG ERROR	Checksum error detected during run-up	Part program file system in FLASH has been destroyed	Check if programming procedure was interrupted by power failure. If yes: reload part program. If no: replace hardware.
F112	DATA ERROR	Error during data transfer to the V24 interface	Faults in wiring. Interface configurator malfunctional	Check leads, install screen, check interface configuration.

**A.1.1 Dansk****Sikkerhedshenvisningerne i denne
brugsanvisning**

Disse symboler anvendes i den foreliggende brugsanvisning i følgende tilfælde:

**FORSIGTIG**

Dette symbol benyttes, hvis der skal advares mod **farlig elektrisk spænding**. Hvis advarslen ikke følges nøjagtigt eller ignoreres kan det medføre **personskader**.

**FORSIGTIG**

Dette symbol benyttes, hvis en unøjagtig eller manglende overholdelse af anvisningerne kan medføre beskadigelser af **personer**.

**VIGTIGT**

Dette symbol benyttes, hvis en unøjagtig eller manglende overholdelse af anvisningerne kan medføre beskadigelser af **apparater eller filer**.



Dette symbol benyttes for at gøre Dem opmærksom på noget særligt.

**FORSIGTIG**

0.1

Risiko for personer og ting!

Prøv hvert nyt program, inden De tager et anlæg i drift!

**VIGTIGT**

0.2

Risiko for modulet!

Modulet må ikke sættes i eller trækkes ud af stikket, når der er tændt for styringen! Modulet kan blive ødelagt. Der skal først slukkes for styringens netdelmodul, den eksterne spændingsforsyning og signalspændingen eller disse skal trækkes ud af stikket, inden modulet må sættes i eller trækkes ud af stikket!

**VIGTIGT**

0.3

Risiko for modulet!

Ved omgang med modulet skal alle forholdsregler til ESD-beskyttelse iagttages!

Undgå elektrostatiske udladninger!

**VIGTIGT**

2.1

Gennemsnitstemperaturen for luften i omgivelserne må ikke overstige 50° over en periode på 24 timer!

**VIGTIGT**

2.2

Luften i omgivelserne skal være fri for høje koncentrationer af støv, syre, lud, korrosionsmidler, salte, metaldampe eller andre elektrisk ladede urenheder. Kondensdannelse er ikke tilladt.

**VIGTIGT**

2.3

Der må ikke optræde nogen stærke elektromagnetiske områder i umiddelbar nærhed af apparatet.



VIGTIGT

3.1

For at kunne trække betjeningsfeltet af under driften, skal NØDSTOP kortsluttes i tilpasningsstyringen for at undertrykke funktionen NØDSTOP på maskinen.



FORSIGTIG

4.1

Ved opbygningen af strømforsyningen skal de gældende normer og forskrifter overholdes. Dette gælder især VDE-bestemmelserne (f. eks. VDE 0100 og VDE 0113) og det lokale energiforsynings-selskabs bestemmelser!

Alle tilslutningskabler skal udføres, som vist i blokdiagrammerne!

El-tilslutningen må kun udføres af dertil kvalificeret personale. Der skal anvendes egnet elektroværktøj. Der skal principielt anvendes transformatorer iht. VDE 0551!



VIGTIGT

4.2

Ved apparater, som drives med netspænding, skal det før ibrugtagningen kontrolleres, om det indstillede/krævede netspændingsområde stemmer overens med spændingen på stedet. Udsving eller afvigelser i netspændingen i forh. til mærkespændingen må ikke over- resp. underskride de angivne tolerancegrænser. I modsat fald kan funktionsudfald og/eller risikotilstande ved elektriske moduler ikke udelukkes.



VIGTIGT

4.3

Anlæggets beskyttelsesledersystem (jordforbindelser) skal opbygges i maskeform. Modulkabinetter, kontrolskabskabinetter, monteringsplader i kontrolskabet m.v. skal tilsluttes beskyttelsesledersystemet. Ved ledningsføringen af beskyttelseslederne skal der især sørges for tilstrækkeligt stort ledningskvadrat!

Potentialudligningsledninger / PE-ledninger for alle anlægsdele (især mellem NC og drev) skal holdes så korte som muligt og dermed med så lavt Ohm-tal som muligt. Modstanden mellem hovedbeskyttelsesledertilslutningen og alle dele i den elektriske udrustning såvel som maskinen må ikke overstige 0,1 W (se EN 60204 del 1)!

Alle afskærmninger skal – under forudsætning af, at anlægsdelene jordingsmæssigt er opbygget i et elektrisk netværk – være tilsluttet på begge sider.

For skærmlederne i drev-nom. værdiledninger skal tilslutningen af disse findes i tilslutningsbetingelserne for de enkelte drev, da der ofte er foreskrevet ensidig tilslutning ved disse ledere.



VIGTIGT

4.4

- Støjdæmpning skal ske så tæt på støjilden som muligt.
- Begrænsning af afledningsstrøm iht. sikkerhedsbestemmelserne (berøringsbeskyttelse)
- Støjdæmperdele skal støttes godt mekanisk for at undgå brud pga. vibration.
- Brug kun konstruktionsdele, der er mærket som støjdæmpningsmiddel



VIGTIGT

5.1

Udgangstrinene for CC10 er stabile overfor stationær kortslutning. Hvis flere udgange er kortsluttede, kan der dog opstå ødelæggelse af udgangs-operationsforstærkeren på grund af den øgede tabseffekt.

**VIGTIGT**

5.2

Bryder READY2-kontakten, stilles nom.værdiudgangene straks på 0V (analog-GND). Dette niveau garanteres i højst 1 sekund! Derfor skal drevene frakobles inden for 1 sekund!

**VIGTIGT**

5.3

Servoforstærker med GND-behæftet indgang må ikke tilsluttes på CC10.

**VIGTIGT**

5.4

Ved anvendelse af en EXE eller en føler for direkte tilslutning med signal Uas skal det kontrolleres, at ledningsføringen for signal Uas til CC10 er rigtig! Åbne Uas-indgange lægges via interne pull-up-modstande på High-Potential (ingen aktive målesystemfejl).

**VIGTIGT**

7.1

Efter indkobling af styringen resp. under initialiseringsfasen for CC 10 er tilstandene for interfacesignalerne endnu ikke definerede. Interfacesignalerne har først definerede tilstande, når CC 10 er "driftsklar", dvs. at kontakten "Ready" på stik X10 er sluttet (grøn LED lyser)...

**VIGTIGT**

7.2

1. Såfremt kun akse 1 er appliceret, kan det anbefales, at definere parameter P0030 til "SYNKRON". I dette tilfælde kræves der 16 byte indgange/udgange mindre end ved "ASYNKRON"-akser.

(Se også maskinparameter-beskrivelse)

2. Ved asynkron-drift med udvidet interface skal der generelt overføres 40 byte standardinterfacedata, selv i tilfælde af, at kun 1 eller 2 akser er appliceret.

Sikkerhedshenvisninger på styrekomponenterne

På styrekomponenterne selv kan der være anbragt følgende advarsler og henvisninger, som skal gøre Dem opmærksom på bestemte ting:



Advarsel mod farlig elektrisk spænding!



Advarsel mod farer fra batterier!



Elektrostatisk udsatte komponenter!



Træk netstikket ud, inden De åbner!



Bolt kun til tilslutning af jordledningen PE!



Kun til tilslutning af en afskærmningsledning!

A.1.2 Deutsch

Sicherheitshinweise in dieser
Gebrauchsanweisung

Diese Symbole werden in dieser Gebrauchsanweisung unter den folgenden Bedingungen verwendet.



VORSICHT

Dieses Symbol wird benutzt, wenn vor einer **gefährlichen elektrischen Spannung** gewarnt werden soll. Durch ungenaues Befolgen oder Nichtbefolgen dieser Anweisung kann es zu **Personenschäden** kommen.



VORSICHT

Dieses Symbol wird benutzt, wenn es durch ungenaues Befolgen oder Nichtbefolgen von Anweisungen zu **Personenschäden** kommen kann.



ACHTUNG

Dieses Symbol wird benutzt, wenn es durch ungenaues Befolgen oder Nichtbefolgen von Anweisungen zu **Beschädigungen von Geräten oder Dateien** kommen kann.



Dieses Symbol wird benutzt, wenn Sie auf etwas Besonderes aufmerksam gemacht werden sollen.



VORSICHT

0.1

Gefahr für Personen und Sachen!

Testen Sie jedes neue Programm bevor Sie eine Anlage in Betrieb nehmen!



ACHTUNG

0.2

Gefahr für die Baugruppe!

Baugruppe nicht bei eingeschalteter Steuerung stecken oder ziehen! Baugruppe kann zerstört werden. Zuerst Netzteilbaugruppe der Steuerung, externe Spannungsversorgung und Signalspannung ausschalten oder abziehen und erst dann Baugruppe stecken oder ziehen!



ACHTUNG

0.3

Gefahr für die Baugruppe!

Beim Umgang mit der Baugruppe müssen alle Vorkehrungen zum ESD-Schutz eingehalten werden! Elektrostatische Entladungen vermeiden!



ACHTUNG

2.1

Die Durchschnittstemperatur der Umgebungsluft darf über einen Zeitraum von 24 Stunden 50 5C nicht übersteigen!



ACHTUNG

2.2

Die Umgebungsluft muß frei sein von höheren Konzentrationen an Staub, Säuren, Laugen, Korrosionsmitteln, Salzen, Metaldämpfen oder anderen elektrisch leitenden Verunreinigungen. Eine Betauung ist nicht zulässig.



ACHTUNG

2.3

In direkter Nähe der Geräte dürfen keine starken elektromagnetischen Felder auftreten.

**ACHTUNG****3.1**

Um das Bedienfeld während des Betriebes abziehen zu können, muß in der Anpaßsteuerung NOT–AUS überbrückt werden, um die Funktion NOT–AUS an der Maschine zu unterdrücken.

**VORSICHT****4.1**

Beim Aufbau der Netzversorgung sind die einschlägigen Normen und Vorschriften zu berücksichtigen. Es sind insbesondere die VDE–Bestimmungen (z. B. VDE 0100 und VDE 0113) und die Bestimmungen des örtlichen E–Werks zu beachten!

Alle Anschlußkabel sind so auszuführen wie in den Blockschaltbildern gezeigt!

Der elektrische Anschluß darf nur von entsprechend qualifiziertem Personal durchgeführt werden. Dabei ist geeignetes Elektrowerkzeug zu verwenden. Es müssen prinzipiell Trafos nach VDE 0551 verwendet werden!

**ACHTUNG****4.2**

Bei Geräten, die mit Netzspannung betrieben werden, muß vor der Inbetriebnahme überprüft werden, ob der eingestellte/geforderte Netzspannungsbereich mit der örtlichen Netzspannung übereinstimmt.

Schwankungen oder Abweichungen der Netzspannung vom Nennwert dürfen die angegebenen Toleranzgrenzen nicht über– bzw. unterschreiten. Andernfalls sind Funktionsausfälle und/oder Gefährdungen an den elektrischen Baugruppen nicht auszuschließen

**ACHTUNG****4.3**

Das Schutzleitersystem (Erdverbindungen) der Anlage ist maschenförmig aufzubauen!

Modulgehäuse, Schaltschrankgehäuse, Montageplatten im Schaltschrank usw. sind an das Schutzleitersystem anzuschließen. Bei der Schutzleiterverdrahtung ist besonders auf ausreichenden Leitungsquerschnitt zu achten!

Die Potentialausgleichsleitungen/PE–Leitungen aller Anlagenteile (besonders zwischen NC und Antrieben) müssen möglichst kurz und damit niederohmig gehalten werden. Der Widerstand zwischen dem Hauptschutzleiteranschluß und allen Körpern der elektrischen Ausrüstung sowie der Maschine darf 0.1 Ω nicht übersteigen (siehe EN 60204 Teil1)!

Alle Abschirmungen müssen –unter der Voraussetzung, daß die Anlagenteile erdungsmäßig elektrisch vernetzt aufgebaut sind– beidseitig aufgelegt sein.

Für die Schirmleiter von Antriebs–Sollwertleitungen ist deren Anschluß den Anschlußbedingungen der einzelnen Antrieben zu entnehmen, da dort manchmal einseitiger Anschluß vorgeschrieben ist.

**ACHTUNG****4.4**

- Entstörung möglichst dicht am Störer.
- Ableitströme gemäß Sicherheitsbestimmungen begrenzen (Berührungsschutz!).
- Entstörglieder mechanisch gut unterstützen, um Bruch durch Vibration zu vermeiden.
- Nur als Entstörmittel gekennzeichnete Bauteile verwenden



ACHTUNG

5.1

Die Ausgangsstufen der CC10 sind dauerkurzschlußfest. Sind jedoch mehrere Ausgänge kurzgeschlossen, kann es durch die erhöhte Verlustleistung zur Zerstörung der Ausgangs-Operationsverstärker kommen.



ACHTUNG

5.2

Öffnet der READY2-Kontakt, werden die Sollwertausgänge sofort auf 0V (Analog-GND) gesetzt. Dieser Pegel wird für höchstens 1 sek garantiert! Deshalb müssen die Antriebe innerhalb von 1 sek abgeschaltet werden!



ACHTUNG

5.3

Servoverstärker mit GND-behaftetem Eingang dürfen nicht an die CC10 angeschlossen werden.



ACHTUNG

5.4

Bei Verwendung einer EXE oder eines Gebers für Direktanschluß mit Signal Uas ist die richtige Verdrahtung des Signals Uas zur CC10 hin zu prüfen! Offene Uas-Eingänge werden durch interne Pull-Up-Widerstände auf High-Potential (kein anstehender Meßsystemfehler) gelegt.



ACHTUNG

7.1

Nach dem Einschalten der Steuerung bzw. während der Initialisierungsphase der CC 10 sind die Zustände der Interfacesignale noch nicht definiert. Die Interfacesignale haben erst dann definierte Zustände, wenn die CC 10 "Betriebsbereit" ist, d.h. der Kontakt "Ready" auf Stecker X10 ist geschlossen (grüne LED leuchtet).



ACHTUNG

7.2

1. Sofern nur 1 Achse appliziert ist, empfiehlt es sich, den Parameter P0030 auf "SYNCHRON" zu definieren. In diesem Fall werden 16 Byte Eingänge/Ausgänge weniger benötigt als bei "ASYNCHRON"-Achsen.

(Siehe auch Maschinenparameter-Beschreibung)

2. Bei Asynchron-Betrieb mit erweitertem Interface müssen generell 40 Byte Standardinterfacedaten übertragen werden, auch wenn nur 1 oder 2 Achsen appliziert sind.

Sicherheitshinweise an den Steuerungskomponenten

An den Steuerungskomponenten selbst können folgende Warnungen und Hinweise angebracht sein, die Sie auf bestimmte Dinge aufmerksam machen sollen:



Warnung vor gefährlicher elektrischer Spannung!



Warnung vor Gefahren durch Batterien!



Elektrostatisch gefährdete Bauelemente!



Vor dem Öffnen Netzstecker ziehen!



Bolzen nur für Anschluß des Schutzleiters PE!



Nur für Anschluß eines Schirmleiters!

A.1.3 Ελληνικά

Υποδείξεις ασφαλείας στις παρούσες οδηγίες χρήσεως



Τα σύμβολα αυτά στις παρούσες οδηγίες χρήσεως χρησιμοποιούνται υπό τους ακόλουθους όρους:



ΚΙΝΔΥΝΟΣ

Αυτό το σύμβολο χρησιμοποιείται για να σας προειδοποιήσει από επικίνδυνη ηλεκτρική τάση. Αν δεν τηρούνται με ακρίβεια ή δεν τηρούνται καθόλου οι οδηγίες μπορεί να προκληθούν σωματικές βλάβες.



ΚΙΝΔΥΝΟΣ

Το σύμβολο αυτό χρησιμοποιείται, όταν μπορεί να προκληθούν σωματικές βλάβες, αν δεν τηρούνται με ακρίβεια ή δεν τηρούνται καθόλου οδηγίες.



ΠΡΟΣΟΧΗ

Το σύμβολο αυτό χρησιμοποιείται, όταν μπορεί να προκληθούν ζημιές σε συσκευές ή σε αρχεία, αν δεν τηρούνται με ακρίβεια ή δεν τηρούνται καθόλου οδηγίες.



Το σύμβολο αυτό χρησιμοποιείται, όταν θα πρέπει να επιστηθεί η προσοχή σας σε κάτι το σημαντικό.



ΚΙΝΔΥΝΟΣ

0.1

Κίνδυνος για πρόσωπα και αντικείμενα!

Δοκιμάστε κάθε καινούριο πρόγραμμα πριν θέσετε μια εγκατάσταση σε λειτουργία!



ΠΡΟΣΟΧΗ

0.2

Κίνδυνος για το στοιχείο κατασκευής!

Μην αφαιρείτε ή τοποθετείτε το στοιχείο κατασκευής σε κύκλωμα που είναι σε λειτουργία! Το στοιχείο κατασκευής μπορεί να καταστραφεί. Πρώτα αφαιρείτε ή αποσυνδέετε το στοιχείο κατασκευής της ρύθμισης του ηλεκτρικού κυκλώματος, κατόπιν την παροχή τάσης και την τάση σήματος και μετά τοποθετείτε ή αφαιρείτε το στοιχείο κατασκευής.



ΠΡΟΣΟΧΗ

0.3

Κίνδυνος για το στοιχείο κατασκευής!

Όταν έχετε στα χέρια σας το στοιχείο κατασκευής πρέπει να τηρείτε όλα τα μέτρα για την ηλεκτροστατική προστασία! Αποφεύγετε ηλεκτροστατικές εκφορτίσεις!



ΠΡΟΣΟΧΗ

2.1

Η μέση θερμοκρασία του περιβάλλοντος αέρα, δεν πρέπει να υπερβαίνει τους 50°C, για ένα χρονικό διάστημα 24 ωρών!



ΠΡΟΣΟΧΗ

2.2

Ο περιβάλλον αέρας πρέπει να είναι ελεύθερος από υψηλές συγκεντρώσεις σκόνης, οξέων, αλκαλικών διαλυμάτων, αλάτων, αναθυμιάσεις μετάλλων ή από άλλες ακαθαρσίες που φέρουν ηλεκτρισμό. Δεν επιτρέπεται οποιαδήποτε επεξεργασία.



ΠΡΟΣΟΧΗ

2.3

Δεν επιτρέπεται να υπάρχουν ηλεκτρομαγνητικά κύματα, γύρω από την συσκευή.

**ΠΡΟΣΟΧΗ**

3.1

Για να μπορέσετε να απομακρύνετε τον πίνακα χειρισμού, πρέπει να γεφυρωθεί η λειτουργία έκτακτης ανάγκης, για να κατασταλεί αυτή η λειτουργία.

**ΚΙΝΔΥΝΟΣ**

4.1

Λαμβάνετε υπ' όψιν σας τις αντίστοιχες οδηγίες και κανονισμούς, κατά την εγκατάσταση της παροχής τάσης. Ιδιαίτερα τους κανονισμούς $\text{☒}\Delta\text{E}$ (π.χ. $\text{☒}\Delta\text{E}$ 0100 και $\text{☒}\Delta\text{E}$ 0113) καθώς και τους κανονισμούς του κατά τόπου εργοστασίου παραγωγής ηλεκτρισμού! Συνδέετε τα καλώδια όπως περιγράφεται στις εικόνες συνδέσεων! Οι ηλεκτρικές συνδέσεις πρέπει να γίνονται από ειδικά εκπαιδευμένο προσωπικό. Πρέπει να χρησιμοποιούνται τα κατάλληλα ηλεκτρικά εργαλεία. Βασικά πρέπει να χρησιμοποιούνται μετασχηματιστές τύπου $\text{☒}\Delta\text{E}$ 0551!

**ΠΡΟΣΟΧΗ**

4.2

Για συσκευές που λειτουργούν με τάση δικτύου, πρέπει πριν από την έναρξη λειτουργίας να ελέγχεται αν η απαιτούμενη τάση συμφωνεί με την κατά τόπο τάση. Αποκλίσεις ή διακυμάνσεις της τάσης του δικτύου από την τάση της συσκευής, δεν πρέπει να υπερβαίνουν ή να βρίσκονται κάτω από τα προκαθορισμένα όρια ανοχής. Διαφορετικά δεν αποκλείονται διαταραχές στην λειτουργία ή/και επικίνδυνες καταστάσεις στα ηλεκτρικά στοιχεία κατασκευής.

**ΠΡΟΣΟΧΗ**

4.3

Εγκαταστήστε δικτυωτά το σύστημα προστασίας αγωγών (γείωσεις) της εγκατάστασης!

**ΠΡΟΣΟΧΗ**

Συνδέστε τα κουτιά των ηλεκτρονικών στοιχείων, τα κουτιά των διακοπών και τις πλάκες συναρμολόγησης στους διακόπτες με το σύστημα προστασίας αγωγών. Φροντίστε για την επαρκή διατομή των καλωδίων κατά τη σύνδεση!

**ΠΡΟΣΟΧΗ**

Οι συνδέσεις ισορροπίας δυναμικού / PE-αγωγοί, όλων των μερών της εγκατάστασης (ιδιαίτερα μεταξύ ΝΞ και προώθησης) πρέπει να είναι βραχείς και με λίγα Ω. Η αντίσταση μεταξύ της σύνδεσης του κύριου αγωγού προστασίας και όλων των άλλων μερών της ηλεκτρικής εγκατάστασης καθώς και της μηχανής, δεν πρέπει να υπερβαίνει τα 0.1 Ω (βλέπε EN 60204 Μέρος 1)!

**ΠΡΟΣΟΧΗ**

Όλες οι προκαλύψεις πρέπει -με την προϋπόθεση ότι τα μέρη έχουν εγκατασταθεί ηλεκτρικά με γείωση- να εναποτίθενται και από τις δυο πλευρές. Για τους προστατευτικούς αγωγούς των αγωγών προώθησης, συμβουλευτείτε για την σύνδεσή τους τις συνθήκες σύνδεσης των επιμέρους προωθήσεων, γιατί καμιά φορά προβλέπεται γι' αυτές μονόπλευρη σύνδεση.

**ΠΡΟΣΟΧΗ**

-1-

**ΠΡΟΣΟΧΗ**

4.4

- Αποκατάσταση των διαταραχών όσο το δυνατόν κοντά στον διαταρακτή.- Περιορισμός των παράγωγων ρευμάτων, με βάση τις οδηγίες ασφαλείας (προστασία επαφής!). Υποστηρίξτε καλά μηχανικά τα μέλη αποκατάστασης διαταραχών, για την αποφυγή θραύσεων λόγω δονήσεων.- Χρησιμοποιείτε σαν μέσα αποκατάστασης διαταραχών, διακεκριμένα στοιχεία κατασκευής.

**ΠΡΟΣΟΧΗ**

5.1

Οι έξοδοι του ΞΞ 10 είναι ασφαλισμένοι από βραχυκύκλωμα. Αν παρ' όλα αυτά είναι κάποιες έξοδοι βραχυκυκλωμένοι, υπάρχει περίπτωση να καταστραφούν οι ενισχυτές λειτουργίας στις εξόδους, λόγω των αυξημένων απωλειών ισχύος.

**ΠΡΟΣΟΧΗ**

5.2

Όταν ανοίγει η επαφή ΡΕΑΔΨ2 έρχονται οι έξοδοι αμέσως στα 0 Ω. Αυτή η στάθμη είναι εγγυημένη για τουλάχιστον 1 δευτερόλεπτο! Γι' αυτό και πρέπει οι προωθήσεις να διακοπούν μέσα σ' ένα δευτερόλεπτο!

**ΠΡΟΣΟΧΗ**

5.3

Ο σερβοενισχυτές ΓΝΔ με έξοδο, δεν πρέπει να συνδέονται στο ΞΞ 10.

**ΠΡΟΣΟΧΗ**

5.4

Κατά τη χρήση ενός ΕΧΕ ή ενός μετατροπέα άμεσης σύνδεσης με σήμα Υασ, ελέγξτε για την σωστή καλωδίωση του σήματος Υασ στο ΞΞ 10! Οι ανοικτές έξοδοι Υασ μετατρέπονται μέσω εσωτερικών αντιστάσεων τύπου πυλλ-υπ σε εξόδους υψηλού δυναμικού (κανένα υφιστάμενο σφάλμα του συστήματος μέτρησης).

**ΠΡΟΣΟΧΗ**

7.1

Μετά το άνοιγμα της ρύθμισης και κατά τη διάρκεια της φάσης ενεργοποίησης του ΞΞ 10, δεν είναι ακόμα ορισμένη η κατάσταση των σημάτων. Τα σήματα των μεταβατικών σημείων, αποκτούν μια ορισμένη κατάσταση όταν το ΞΞ 10 είναι "έτοιμο προς λειτουργία", δηλαδή η επαφή "Ρεαδψ" στην πρίζα Χ10 είναι κλεισμένη (η πράσινη λυχνία ανάβει).....

**ΠΡΟΣΟΧΗ**

7.2

1. Αν υπάρχει μόνο ένας άξονας, συνιστάται να ορίσετε την παράμετρο Ρ0030 σαν "ΣΨΝΞΗΡΟΝ". Σ' αυτή την περίπτωση απαιτούνται 16 Βψτε εισοδου/έξοδοι λιγότερα, από τους άξονες "ΑΣΨΝΞΗΡΟΝ". (Βλέπε ακόμα παράμετρους μηχανής - Περιγραφή)

**ΠΡΟΣΟΧΗ**

2. Σε λειτουργία "Ασπνξηρον" με επεκτεταμένα μεταβατικά σημεία, πρέπει γενικά να μεταδοθούν 40 Βψτε δεδομένα μεταβατικών σημείων, ακόμα και αν υπάρχουν 1 ή 2 άξονες.

Υποδείξεις ασφαλείας σε εξαρτήματα ρύθμισης και ελέγχου

Τα εξαρτήματα ρύθμισης και ελέγχου μπορεί να φέρουν τις ακόλουθες προειδοποιήσεις και υποδείξεις, που επιστούν την προσοχή σας σε ορισμένα πράγματα:



Προειδοποίηση σχετικά με επικίνδυνη τάση ηλεκτρικού ρεύματος!



Προειδοποίηση σχετικά με κινδύνους, που προέρχονται από μπαταρίες!



Στοιχεία κατασκευής, για τα οποία υπάρχει ηλεκτροστατικός κίνδυνος!



Πριν από το άνοιγμα βγάλτε το φισ από την πρίζα!



Πείροι μόνο για σύνδεση προστατευτικού αγωγού (γείωσης) PE!



Μόνο για σύνδεση θωρακισμένου αγωγού!

A.1.4 Español

Indicaciones de seguridad en estas instrucciones de empleo



Estos símbolos se utilizan en estas instrucciones de empleo bajo las siguientes condiciones.



PRECAUCION

Este símbolo se utiliza para advertir de una **tensión eléctrica peligrosa**. La ejecución inexacta o la no ejecución de esta instrucción podrá provocar **daños a las personas**.



PRECAUCION

Este símbolo se utiliza cuando por una ejecución inexacta o la no ejecución de instrucciones se pueden llegar a producir **daños a las personas**.



ATENCION

Este símbolo se utiliza cuando por la ejecución inexacta o la no ejecución de instrucciones se pueden llegar a producir **daños en los aparatos o archivos**.



Este símbolo se utiliza cuando se le debe llamar la atención respecto a algo especial.



PRECAUCION

0.1

¡Peligro para personas y bienes materiales!
¡Compruebe cada nuevo programa antes de poner en funcionamiento una instalación!



ATENCION

0.2

¡Peligro para el módulo!
¡No enchufe ni extraiga el módulo cuando el control está conectado! Puede destruirse el módulo. ¡Desconecte o desenchufe primero el módulo de fuente de alimentación del control, la alimentación de tensión externa y la tensión de señalización y sólo después enchufe o extraiga el módulo!



ATENCION

0.3

¡Peligro para el módulo!
¡Observe en la manipulación del módulo todas las precauciones en cuanto a la protección ESD! ¡Evite descargas estáticas!



ATENCION

2.1

La temperatura media del aire ambiente no deberá exceder de 50 °C durante un período de 24 horas.



ATENCION

2.2

El aire ambiente debe estar libre de mayores concentraciones de polvo, ácidos, lejías, agentes corrosivos, sales, vapores metálicos u otras impurezas eléctricamente conductoras. No debe haber ninguna condensación.



ATENCION

2.3

En las inmediaciones de los aparatos no deberán presentarse fuertes campos electromagnéticos.

**ATENCIÓN****3.1**

Para que se pueda extraer el panel de mando durante la operación, deberá puentearse el contacto de DESCONEJON DE EMERGENCIA en el control de adaptación para suprimir la función de DESCONEJON DE EMERGENCIA en la máquina.

**ATENCIÓN****PRECAUCION****4.1**

Al establecer la alimentación de red tendrán que considerarse las normas y prescripciones pertinentes. En particular, deberán observarse las disposiciones VDE (p.ej. VDE 0100 y VDE 0113) y las prescripciones de la compañía local de suministro de energía eléctrica.

El tendido de todos los cables de conexión deberá efectuarse conforme a los diagramas de bloque.

La conexión eléctrica deberá ser efectuada únicamente por personal que tenga la calificación correspondiente, utilizándose las herramientas eléctricas apropiadas. Tendrán que usarse fundamentalmente transformadores según VDE 0551.

**ATENCIÓN****4.2**

En los aparatos que se operen con tensión de red habrá que comprobar antes de la puesta en funcionamiento si el margen de tensión de red requerido/ajustado coincide con la tensión de la red local. Las fluctuaciones o desviaciones de la tensión de red del valor nominal no deberán sobrepasar o quedar por debajo de los límites de tolerancia señalados. En caso contrario, no podrán excluirse fallos de funcionamiento y/o estados peligrosos en los módulos eléctricos.

**ATENCIÓN****4.3**

El sistema de los conductores protectores (conexiones a tierra) de la instalación deberá establecerse en forma de mallas.

El encapsulado de los módulos y armarios, las placas de montaje en el armario de distribución, etc. deberán conectarse al sistema de conductores protectores. En el cableado de los conductores protectores habrá que tener en cuenta que los mismos tengan una sección transversal suficiente.

Los cables de conexión equipotencial / cables PE de todas las partes de la instalación (particularmente entre el NC y los accionamientos) deben ser lo más cortos posible y, por tanto, de bajo ohmiaje. La resistencia entre la conexión del conductor protector principal y todos los cuerpos del equipo eléctrico y de la máquina no debe ser superior a 0.1 (véase EN 60204 parte 1^a). Bajo la condición de que las partes de la instalación estén diseñadas de forma eléctricamente mallada, todos los blindajes deben estar colocados en ambos lados.

Para la conexión de los conductores de blindaje de cables de valores nominales de accionamientos, véase las condiciones de conexión de los respectivos accionamientos, ya que en este caso a veces está prescrita la conexión unilateral.

**ATENCIÓN****4.4**

Desparasitaje lo más cerca posible del dispositivo productor de las interferencias.

Limitar las corrientes de escape conforme a las disposiciones de seguridad (protección contra contacto accidental).

Sujetar bien mecánicamente los elementos de blindaje antiparasitario para evitar roturas por vibración.

Utilizar únicamente componentes identificados como elementos de blindaje antiparasitario.



ATENCION

5.1

Las etapas de salida del CC10 están resistentes al cortocircuito sostenido. Pero si varias salidas están puestas en cortocircuito, podrán destruirse los amplificadores operacionales de salida debido a la elevada energía disipada.



ATENCION

5.2

Al abrir el contacto READY2, las salidas de valores nominales son puestas inmediatamente a 0V (GND analógico). Este nivel se garantiza para un máximo de 1 segundo. Por este motivo, los accionamientos deben desconectarse dentro de 1 segundo.



ATENCION

5.3

No deberán conectarse al CC10 los servoamplificadores que tengan aplicadas GND a la entrada.



ATENCION

5.4

En caso de usar una EXE o un codificador para conexión directa con señal Uas hay que comprobar el cableado correcto de la señal Uas al CC10.

Las entradas de Uas abiertas son puestas a potencial High mediante resistencias pull-up (no significa ningún error del sistema de medición).



ATENCION

7.1

Después de conectar el control, o sea, durante la fase de inicialización del CC10 aun no están definidos los estados de las señales de interface. Las señales de interface tendrán estados definidos sólo cuando el CC10 está listo para el funcionamiento, es decir, cuando el contacto Ready en el conector X10 está cerrado (LED verde iluminado).



ATENCION

7.2

1. En caso de que esté aplicado un solo eje, es recomendable definir el parámetro P0030 a SINCRONICO. De este modo, se necesitarán 16 bytes menos de entradas/salidas que en caso de ejes ASINCRONICOS.

(véase también la descripción de los parámetros de máquina)

2. En caso de operación asincrónica con interface ampliado, se deben transmitir siempre 40 bytes de datos de interface estándar, aún cuando estén aplicados sólo 1 ó 2 ejes.

Indicaciones de seguridad en los componentes de control

En los componentes de control mismos pueden estar dispuestos las siguientes advertencias e indicaciones que le deben llamar la atención sobre determinados temas:



¡Advertencia ante tensión eléctrica peligrosa!



¡Advertencia ante riesgos por baterías!



¡Elementos constructivos con riesgos de descargas electrostáticas!



¡Antes de abrir, desenchufar el conector de la red!



¡Perno sólo para la conexión del conductor protector PE!



¡Sólo para la conexión de un conector blindado!

A.1.5 Français

Directives de sécurité relatives au présent mode d'emploi



Ces symboles sont utilisés dans les conditions suivantes:



DANGER

Ce symbole est utilisé lorsque l'on veut mettre en garde contre une **tension électrique dangereuse**. Risque de **dommage corporel** si les consignes données ne sont pas respectées ou lorsqu'elles sont mal respectées.



DANGER

Ce symbole est utilisé s'il y a un risque de **dommage corporel** si les consignes données ne sont pas respectées ou lorsqu'elles sont mal respectées.



ATTENTION

Ce symbole est utilisé s'il y a un risque de dommage matériel ou risque de destruction de fichier si les consignes données ne sont pas respectées ou lorsqu'elles sont mal respectées.



Ce symbole est utilisé lorsqu'il s'agit d'attirer votre attention sur un point particulier.



DANGER

0.1

Risque pour les personnes et le matériel !
Testez chaque nouveau programme avant de mettre une installation en service!



ATTENTION

0.2

Risque pour l'unité !
Ne branchez ou ne débranchez pas l'unité lorsque la commande est activée ! Risque de destruction de l'unité. Avant de brancher ou de débrancher l'unité, coupez ou déconnectez d'abord le bloc d'alimentation de la commande, l'alimentation en courant électrique externe et la tension de signal !



ATTENTION

0.3

Risque pour l'unité !
Respectez toutes les mesures de protection ESD lors du maniement de l'unité ! Evitez les décharges électrostatiques !



ATTENTION

2.1

La température moyenne de l'air ambiant ne doit pas dépasser 50 °C pendant un intervalle supérieur à 24 heures !



ATTENTION

2.2

L'air ambiant doit être exempt de concentrations élevées en poussières, acides, bases, agents corrosifs, sels, vapeurs métalliques ou autres impuretés conductrices. Un dégel n'est pas admis.



ATTENTION

2.3

Aucun champ électromagnétique intense ne doit apparaître à proximité directe des appareils.



ATTENTION

3.1

Pour pouvoir retirer le panneau de commande au cours du fonctionnement, la connexion ARRET D'URGENCE doit être court-circuitée dans la commande d'adaptation afin de supprimer la fonction ARRET D'URGENCE au niveau de la machine.



DANGER

4.1

Respecter les normes et les consignes applicables lors du montage de l'alimentation au réseau. Respecter en particulier les prescriptions VDE (par ex. VDE 0100 et VDE 0113) et les prescriptions en vigueur dans l'usine électrique locale !

Tous les câbles de connexion sont montés comme indiqué dans les blocs fonctionnels !

Seul un personnel qualifié en la matière est habilité à effectuer les connexions électriques. Utiliser un outillage électrique approprié à cet effet. La norme VDE 0551 prescrit principalement l'utilisation de transformateurs !



ATTENTION

4.2

Avant la mise en marche, contrôler si la plage de tensions du réseau réglée/exigée coïncide avec la tension du réseau local dans le cas d'appareils alimentés par la tension du réseau. Les fluctuations ou les déviations de la tension du réseau par rapport à la valeur nominale ne doivent pas dépasser les limites de tolérance indiquées ou chuter sous ces limites. Si tel est pourtant le cas, les défaillances de fonctionnement et/ou les états à risque au niveau des éléments électriques ne sont pas exclus.



ATTENTION

4.3

Effectuer le montage du système conducteur de protection (raccordements à la terre) de l'installation sous forme de mailles !

Connecter les carters de modules, les carters d'armoires de commande électriques, les plaques de montage disposées à l'intérieur de l'armoire de commande électrique etc. au système conducteur de protection. Veiller en particulier à une section de lignes électriques suffisante lors du câblage du système conducteur de protection !

Les lignes électriques d'équilibrage de potentiel / les lignes électriques PE de toutes les pièces de l'installation (en particulier entre la commande numérique NC et les entraînements) doivent être maintenues aussi courtes que possible et à des résistances faibles. La résistance entre la connexion du conducteur de protection principal et tous les éléments de l'équipement électrique ainsi que la machine ne doit pas dépasser 0,1 ohm (voir EN 60204 partie 1) !

Tous les blindages doivent être placés sur les deux côtés, dans l'hypothèse où les pièces de l'installation sont montées en réseau électrique et reliées à la terre. Dans le cas des conducteurs-écran des lignes électriques de consigne des entraînements, retirer la connexion en respectant les conditions de connexion des différents entraînements car une connexion unilatérale est parfois prescrite.



ATTENTION

4.4

- Blindage le plus proche possible de la source parasite.
- Limiter les courants de fuite en fonction des consignes de sécurité (protection de contact !).
- Etayer correctement l'élément d'antiparasitage de façon mécanique pour éviter une rupture par vibration.
- Utiliser uniquement des éléments reconnus comme dispositifs d'antiparasitage.

**ATTENTION**

5.1

Les plots de sortie de CC10 sont résistants aux courts-circuits permanents. Cependant, si plusieurs sorties sont court-circuitées, ceci peut mener à la destruction des amplificateurs opérationnels de sortie en raison des pertes en puissance accrues.

**ATTENTION**

5.2

Si le contact READY2 s'ouvre, les sorties de consigne sont immédiatement placées sur 0V (analogique GND). Ce niveau est garanti pour 1 seconde au maximum ! C'est pourquoi les entraînements doivent être coupés en l'espace d'1 seconde.

**ATTENTION**

5.3

Les servoamplificateurs à entrée de maintien GND ne doivent pas être connectés à CC10.

**ATTENTION**

5.4

Contrôler le câblage correct du signal Uas vers CC10 lors de l'utilisation d'un EXE ou d'un transmetteur pour connexion directe avec le signal Uas !

Les entrées Uas ouvertes sont réglées sur un potentiel élevée (pas de défaut apparent de l'appareil de mesure) au moyen de résistances internes Pull-Up.

**ATTENTION**

7.1

Les états des signaux d'interface ne sont pas encore définis après enclenchement de la commande ou au cours de la phase d'initialisation de CC10. Les signaux d'interface ne sont affectés à un état défini que lorsque CC10 est "prêt à fonctionner", c.-à-d. lorsque le contact "Ready" est fermé sur le contacteur X10 (la diode électroluminescente verte s'allume).

**ATTENTION**

7.2

1. Dans la mesure où seul l'axe 1 est appliqué, il est recommandé de définir le paramètre P0030 sur "SYNCHRON". Dans ce cas, les entrées/sorties 16 bytes sont moins nécessaires que dans le cas d'axes "ASYNCHRONES".

(voir aussi la description des paramètres de la machine).

2. En fonctionnement asynchrone avec interface étendue, des données d'interface standard 40 bytes doivent généralement être transmises, même lorsque seuls 1 ou 2 axes sont appliqués.

Mesures de sécurité relatives aux dispositifs de commande

Les pictogrammes et messages d'avertissement suivants peuvent se trouver sur les éléments de commande afin d'attirer votre attention sur certains points:



Présence de tension électrique dangereuse



Danger lié à la présence de batteries



Modules sensibles à l'électricité statique



Enlever la fiche secteur avant l'ouverture



Uniquement pour le raccordement de la terre PE !



Uniquement pour le raccordement d'un câble blindé

A.1.6 Italiano

Avvertenze per la sicurezza in queste istruzioni per l'uso



Questi simboli vengono impiegati in queste istruzioni per l'uso nelle seguenti condizioni.



PERICOLO

Questo simbolo viene impiegato per segnalare la presenza di **tensioni elettriche pericolose**. La mancata osservanza, anche parziale, di queste istruzioni può provocare danni alle **persone**.



PERICOLO

Questo simbolo viene impiegato qualora l'osservanza imprecisa o la mancata osservanza delle istruzioni possono provocare danni alle **persone**.



ATTENZIONE

Questo simbolo viene impiegato qualora l'osservanza imprecisa o la mancata osservanza delle istruzioni può provocare danni agli **apparecchi o ai file**.



Questo simbolo viene impiegato quando si voglia richiamare l'attenzione su qualcosa di particolare.



PERICOLO

0.1

Pericolo per persone ed oggetti!

Provare ogni nuovo programma prima di mettere in funzione l'impianto!



ATTENZIONE

0.2

Pericolo per il modulo!

Non innestare o rimuovere il modulo quando il comando è acceso! Il modulo potrebbe venire distrutto. Spegnerne prima il modulo d'alimentazione del comando, l'alimentazione esterna di tensione e la tensione del segnale e solo successivamente innestare o rimuovere il modulo!



ATTENZIONE

0.3

Pericolo per i moduli!

Durante operazioni con i moduli rispettare tutte le misure di protezione ESD! Evitare scariche elettrostatiche!



ATTENZIONE

2.1

La temperatura media dell'aria dell'ambiente non deve superare i 50 °C per un arco di oltre 24 ore!



ATTENZIONE

2.2

L'aria dell'ambiente non deve presentare elevate concentrazioni di polvere, acidi, basi, prodotti corrosivi, sali, vapori di metallo o altre impurità conduttrici. Non è ammessa la formazione di condensa.



ATTENZIONE

2.3

Nelle immediate vicinanze delle apparecchiature non devono essere presenti elevati campi magnetici.

**ATTENZIONE****3.1**

Per poter estrarre il pannello di comando durante l'esercizio è necessario cavallottare l'ARRESTO D'EMERGENZA presente nel comando di adattamento, per escluderne il funzionamento.

**PERICOLO****4.1**

Durante l'installazione dell'alimentazione di rete bisogna rispettare le relative norme e prescrizioni vigenti. In particolare vanno rispettate le disposizioni delle Associazioni Elettrotecniche (in Germania VDE, per es. VDE 0100 e VDE 0113) e quelle degli enti erogatori di energia locali!

Tutti i cavi devono essere installati come descritto negli schemi elettrici a blocchi!

I collegamenti elettrici devono essere eseguiti esclusivamente da personale corrispondentemente qualificato. Per questa operazione bisogna impiegare utensili adatti. Devono essere sempre impiegati trasformatori conformi alla norma VDE 0551!

**ATTENZIONE****4.2**

Con apparecchi alimentati dalla rete bisogna controllare prima della messa in funzione che l'intervallo di tensione impostato/necessario sia compatibile con la tensione della rete locale. Oscillazioni o variazioni della tensione di rete rispetto al valore nominale devono essere comprese nella tolleranza indicata e non devono superarla né per eccesso e né per difetto. In caso contrario non sono da escludere guasti dei moduli elettrici e/o situazioni pericolose.

**ATTENZIONE****4.3**

I vari punti del sistema di protezione (collegamento a terra) dell'impianto devono essere collegati tra di loro a maglia!

I contenitori dei moduli, i telai e le piastre di montaggio del quadro elettrico ecc. devono essere collegati al sistema di protezione. Durante il cablaggio della linea di protezione prestare particolare attenzione ad una adeguata sezione dei conduttori!

I conduttori di compensazione della tensione/conduttori PE (messa a terra) di tutte le parti dell'impianto (specialmente tra controllo numerico e azionatori) devono essere possibilmente corti ed offrire una bassa resistenza ohmica. La resistenza tra il collegamento al conduttore di terra principale e tutti i corpi dell'equipaggiamento elettrico non deve superare 0,1 (vedere norma EN 60204 parte 1)!

Tutte le schermature dei conduttori devono – presupposto che la messa a terra delle parti dell'impianto presenti una struttura reticolare – essere collegate da entrambi i lati.

Per il collegamento della schermatura dei conduttori per il segnale del valore nominale degli azionatori bisogna consultare le condizioni di collegamento dei singoli azionatori, dato che a volte viene prescritto un contatto singolo.

**ATTENZIONE****4.4**

– Eseguire la schermatura il più vicino possibile alla fonte di disturbo.

– Limitare le correnti di dispersione conformemente alle prescrizioni di sicurezza (protezione contro le scariche!).

– Gli elementi di schermatura devono essere adeguatamente fissati per evitarne la rottura dovuta a vibrazioni.

– Impiegare solo parti contrassegnate come adatte alla schermatura.

**ATTENZIONE****5.1**

Gli stadi d'uscita del CC 10 sono protetti contro cortocircuiti permanenti. Se, però, sono cortocircuitate più uscite può subentrare la distruzione dell'amplificatore operativo d'uscita a causa dell'elevata potenza dissipata.

**ATTENZIONE**

5.2 Se si apre il contatto READY2 le uscite del valore nominale vengono immediatamente poste a 0V (GND – analogico). Questo livello viene mantenuto al massimo per 1 secondo! Per questo motivo gli azionatori devono spegnersi entro 1 secondo!

**ATTENZIONE****5.3**

Servoamplificatori con ingressi caricati a GND non devono essere collegati al CC 10.

**ATTENZIONE****7.1**

Dopo l'accensione del comando oppure durante la fase di inizializzazione del CC 10 gli stati dei segnali d'interfaccia non sono ancora definiti. I segnali d'interfaccia presentano uno stato definito solo quando il CC 10 è "pronto all'uso" e il contatto "ready" sulla spina X10 è chiuso (il LED verde è acceso).

**ATTENZIONE****7.2**

1. Se viene comandato un solo asse è consigliabile impostare il parametro P0030 su "SYNCHRON". Dato che in questo caso ingressi/uscite a 16 Byte sono meno necessari che con assi "ASYNCHRON". (vedere anche la descrizione dei parametri della macchina)
2. Con il funzionamento asincrono con interfaccia ampliata è necessario in generale trasmettere dati a 40 Byte per interfaccia standard, anche se vengono comandati solo 1 o 2 assi.

Avvertenze per la sicurezza sui componenti di comando

Sui componenti di comando stessi possono essere applicate le seguenti targhette di avvertimento e di avvertenza, che richiamano l'attenzione su particolari pericoli:



Avvertimento per tensione elettrica pericolosa!



Avvertimento per pericoli dovuti alle batterie!



Elementi costruttivi danneggiabili da cariche elettrostatiche!



Sfilare la spina dalla rete prima di aprire!



Perno solo per il collegamento del conduttore di protezione PE!



Solo per il collegamento di un conduttore schermato!

A.1.7 Nederlands

Veiligheidsrichtlijnen in deze gebruiksaanwijzing



Deze symbolen worden in deze gebruiksaanwijzing onder de volgende voorwaarden gebruikt.



Dit symbool wordt gebruikt, als de aandacht op een **gevaarlijke elektrische spanning** gevestigd moet worden. Wordt deze aanwijzing niet precies gevolgd of zelfs genegeerd, dan is **lichamelijk letsel** niet uitgesloten.



Dit symbool wordt gebruikt wanneer door onnauwkeurige of niet-naleving van aanwijzingen **schade aan personen** kan worden berokkend.



Dit symbool wordt gebruikt wanneer door onnauwkeurige of niet-naleving van aanwijzingen **schade aan toestellen of bestanden** kan worden berokkend.



Dit symbool wordt gebruikt wanneer wij u op iets bijzonders willen attent maken.



0.1
Gevaar voor lichamenlijk letsel en materiële schade!
Test elk nieuw programma voor u een installatie opstart!



0.2
Gevaar voor de module!
Als de besturing ingeschakeld is, de module niet insteeken of uittrekken! De module kan hierdoor kapot gaan. De module van het netdeel van de besturing, de externe spanningstoevoer en de signaalspanning uitschakelen of aftrekken en pas dan de module insteeken of uittrekken.



0.3
Gevaar voor de module!
In de omgang met de module alle voorschriften m.b.t. de ESD-beveiliging in acht nemen! Elektrostatische ontladingen vermijden!



2.1
De gemiddelde temperatuur van de omgevingslucht mag over een periode van 24 uur niet boven de 50C komen!



2.2
De omgevingslucht mag geen hoge concentraties stof, zuren, logen, anti-corrosiemiddelen, zouten, metaaldampen of andere elektrisch geleidende verontreinigingen vertonen. Bedauwen is niet toegestaan.



2.3
In de directe omgeving van de apparaten mogen geen sterke elektromagnetische velden optreden.



LET OP

3.1 Om het bedieningsveld tijdens het gebruik eraf te kunnen trekken, moet in de aanpassingsbesturing NOODSTOP overbrugd worden, om de functie NOODSTOP op de machine te onderdrukken.



ATTENTIE

4.1

Tijdens het opbouwen van de netvoeding moeten de desbetreffende normen en voorschriften in acht genomen worden.

Met name de VDE – bepalingen (b.v. VDE 0100 en VDE 0113) en de bepalingen van het plaatselijk elektriciteitsbedrijf in acht genomen worden.!

Alle aansluitsnoeren moeten zo uitgevoerd worden als in de blokschemas getoond!

De elektrische aansluiting mag alleen door overeenkomstig gekwalificeerd personeel uitgevoerd worden. Daarbij moet geschikt elektrogereedschap gebruikt worden. Er moeten principieel transformatoren volgens de VDE 0551 gebruikt worden!



LET OP

4.2

Bij apparaten, die met netspanning gebruikt worden, moet voor het in gebruik nemen gecontroleerd worden, of het ingestelde/vereiste netspanningsgebied met de plaatselijke netspanning overeenstemt. Schommelingen en afwijkingen van de netspanning van de nominale waarde mogen niet boven of onder de opgegeven tolerantiegrenzen komen. Anders kunnen uitval van de werking en/of gevaarlijke toestanden aan de elektrische modules niet uitgesloten worden.



LET OP

4.3

Het aarddraadsysteem (aardverbindingen) van de installatie moet maasvormig opgebouwd worden! Moduulbehuizing, schakelkastbehuizing, montageplaten in de schakelkast enz. moeten op het aarddraadsysteem aangesloten worden. Bij de aarddraadbedrading moet met name op voldoende draaddoorsnede gelet worden!

De potentiaalvereffeningsleidingen / PE – leidingen van alle installatie – onderdelen (met name tussen NC en aandrijvingen) moeten zo kort mogelijk en daardoor laag – resistief gehouden worden. De weerstand tussen de hoofdaarddraadaansluiting en alle onderdelen van de elektrische uitrusting en van de machine mag niet meer dan 0,1 W bedragen (zie EN 60204 deel 1)!

Alle afschermingen moeten – vooropgesteld, dat de onderdelen van de installatie wat de aarding betreft elektrisch met elkaar verbonden zijn opgebouwd zijn. – aan beide kanten opgelegd zijn.

Voor de schermleiding van aandrijvings – gewenste waarde – leidingen moet de aansluiting ervan uit de aansluitvoorwaarden van de afzonderlijke aandrijvingen gehaald worden, aangezien daar soms een eenzijdige aansluiting voorgeschreven is.



LET OP

4.4

- Ontstoring zo dicht mogelijk bij de stoorder.
- Afleidstromen volgens de veiligheidsbepalingen begrenzen (bescherming tegen aanraking).
ontstooronderdelen mechanisch goed ondersteunen om breken door vibratie te voorkomen.
- Alleen als ontstoormiddel gekenmerkte onderdelen gebruiken.



LET OP

5.1

De uitgangstrappen van de CC10 zijn permanent tegen kortsluiting beveiligd. Zijn er echter meerdere uitgangen kortgesloten, dan kan door het verhoogde verliesvermogen de vernietiging van de operationele versterkers van de uitgang optreden.

**LET OP**

5.2

Gaat het READY2-contact open, dan worden de gewenste waarde-uitgangen meteen op OV (analoog-GND) gezet. Dit niveau wordt gedurende ten hoogste 1 sec. gegarandeerd! Daarom moeten de aandrijvingen binnen 1 sec. uitgeschakeld worden!

**LET OP**

5.3

Servoversterkers met GND-belaste ingang mogen niet op de CC10 aangesloten worden.

**LET OP**

5.4

Bij gebruik van een EXE of een geveer voor directe aansluiting met signaal Uas moet de juiste bedrading van het signaal Uas naar de CC10 gecontroleerd worden! Open Uas-ingangen worden door interne pull-up-weerstanden op high-potential (geen optredende meetsysteemfouten) gelegd.

**LET OP**

7.1

Na het inschakelen van de besturing resp. tijdens de initialiseringsfase van de CC10 zijn de toestanden van de interfacesignalen nog niet gedefinieerd. De interfacesignalen hebben pas gedefinieerde toestanden, als de CC10 klaar voor gebruik is, d.w.z. het contact Ready op stekker X10 is gesloten (groene LED brandt).

**LET OP**

7.2

1. Voor zover slechts 1 as toegepast is, is het raadzaam, de parameters P0030 op SYNCHROON te definiëren, in dat geval zijn 16 byte ingangen/uitgangen minder nodig dan bij ASYNCHROON-assen.

(zie ook machineparameter – beschrijving)

2. Bij asynchroon-modus met uitgebreide interface moeten over het algemeen 40 byte standaardinterfa-
cegegevens overgedragen worden, ook als slechts 1 of 2 assen toegepast zijn.

**LET OP**

Veiligheidsaanwijzingen bij de besturingscomponenten

Aan de besturingscomponenten zelf kunnen de volgende waarschuwingen en richtlijnen aangebracht zijn. Zij zijn bedoeld om u op bepaalde zaken te attenderen:



Waarschuwing voor gevaarlijke elektrische spanning.



Waarschuwing voor gevaar veroorzaakt door akku's.



Elektrostatisch gevoelige componenten.



Trek de stekker uit alvorens te openen.



Bouten alleen voor aansluiting van de veiligheidsaarding PE.



Alleen voor aansluiting van een afgeschermde kabel.

A.1.8 Português

Instruções de segurança contidas nas presentes instruções de serviço



Estes símbolos são utilizados nas presentes instruções de serviço nos seguintes casos:



CUIDADO

Este símbolo é utilizado para indicar uma **tensão eléctrica perigosa**. Em caso de não observância ou observância incorrecta desta instrução, existe **perigo de ferimento de pessoas**.



CUIDADO

Este símbolo é utilizado quando existe o **perigo de ferimento de pessoas** por observância incorrecta ou não observância das instruções.



ATENÇÃO

Este símbolo é utilizado quando existe o perigo de danificação de aparelhos ou ficheiros por observância incorrecta ou não observância das instruções.



Este símbolo é utilizado para chamar a atenção para algo de especial.



CUIDADO

0.1

Perigos de ferimentos de pessoas e de danos materiais!

Antes de colocar uma instalação em funcionamento há que experimentar sempre qualquer programa novo!



ATENÇÃO

0.2

Perigo para o módulo!

Não retire ou introduza o módulo quando o comando estiver ligado! O módulo poderá ser danificado. Primeiro desligue ou retire o módulo de alimentação do comando, o cabo alimentador da rede e a tensão de sinal, e em seguida, poderá introduzir ou retirar o módulo!



ATENÇÃO

0.3

Perigo para o módulo!

Na utilização do módulo, respeitar todas as prescrições para a protecção do ESD! Evitar descargas electrostáticas!



ATENÇÃO

2.1

A temperatura média do ar ambiente não deve ultrapassar os 50 °C durante um periodo superior a 24 horas!



ATENÇÃO

2.2

O ar ambiente não pode conter grandes concentrações de pó, ácidos, soluções alcalinas, agentes corrosivos, sais, vapores metálicos ou outras impurezas condutoras. Não é permitida uma condensação de água.



ATENÇÃO

2.3

A máquina não pode encontrar-se perto de campos magnéticos.

**ATENÇÃO****3.1**

Para que seja possível desligar o painel de comando durante o funcionamento da máquina, é necessário curto-circuitar o comando de ajuste EMERGÊNCIA-DESLIGAR, para que a função EMERGÊNCIA-DESLIGAR seja desactivada.

**ATENÇÃO****CUIDADO****4.1**

Ao efectuar as ligações à rede eléctrica, observe as normas e regulamentos correspondentes.

Observe principalmente os regulamentos VDE (Associação dos electricistas alemães) (p.ex., os regulamentos VDE 0100 e VDE 0113) e os regulamentos da central eléctrica local!

Todos os cabos de ligação devem ser instalados como indicado no esquema do circuito!

A ligação eléctrica apenas deve ser efectuada por pessoal técnico qualificado.

**ATENÇÃO****4.2**

No caso de aparelhos que funcionam para ser ligados directamente à rede eléctrica, é necessário controlar antes do aparelho ser colocado a funcionar, se a tensão regulada/necessária corresponde à tensão da rede local.

Oscilações ou desvios em relação ao valor nominal da tensão da rede, não devem ultrapassar os limites inferiores/superiores de tolerância dados. Caso isto aconteça é possível que ocorram falhas e/ou situações de perigo nos módulos eléctricos.

**ATENÇÃO****4.3**

O sistema de condutores de protecção (ligações à terra) do equipamento deve ser disposto em rede!

As caixas dos módulos, os chassis da caixa de distribuição, as placas de montagem dentro da caixa de distribuição, etc., devem ser ligadas ao sistema de condutores de protecção. Ao instalar os condutores de protecção certifique-se que o diâmetro dos cabos seja suficiente!

Os cabos de compensação de potencial / cabos PE de todas as partes dos equipamentos (em especial entre a NC e os mecanismos de accionamento) devem ser o mais curtos possível resultando daí valores baixos de Ohm. A resistência entre a ligação do condutor de protecção principal e todos os elementos do equipamento eléctrico/da máquina não pode ser superior a 0.1W (ver EN 60204 Parte 1)!

As blindagens têm que ser efectuadas em ambos os lados, desde que as partes do equipamento tenham sido ligados à terra em rede.

Para condutores com blindagem de cabos nominais de mecanismos de accionamento, observe as condições de ligação das suas ligações, pois aí é possível que esteja prescrita uma ligação unilateral.

**ATENÇÃO****4.4**

– Supersor de interferências o mais blindado possível junto ao emissor da interferência.

– Limitar correntes de derivação de acordo com os regulamentos de segurança (protecção contra o contacto!).

– Apoiar bem os elementos supersores mecanicamente para evitar rotura provocada por vibração.

– Utilizar como meios de supersão de interferências apenas elementos reconhecidos.



ATENÇÃO

5.1

Os níveis de saída da CC10 suportam curto-circuitos. No entanto, se várias saídas forem curto-circuitadas, isto pode levar à destruição do amplificador operacional de saída provocada pela potência dissipada elevada.



ATENÇÃO

5.2

Quando o contacto READY2 actua, as saídas nominais são colocadas imediatamente em 0V (GND analógico).

Este nível é garantido no máximo durante 1 segundo! Por esta razão, o sistema de accionamento tem que ser desligado durante 1 segundo!



ATENÇÃO

5.3

Servo-amplificadores com entrada com GND não devem ser ligadas à CC10.



ATENÇÃO

5.4

Ao utilizar um EXE ou um emissor para a ligação directa com sinal Uas, verifique a ligação correcta do sinal Uas à CC10!

Entradas Uas activas, são colocados em High-Potential (nenhum erro presente no sistema de medição) através de resistências Pull-Up.



ATENÇÃO

7.1

Ao ligar o comando ou durante a fase de inicialização da CC 10, os estados dos sinais do Interface não estão ainda definidos. Os sinais do Interface apenas serão definidos, quando a CC 10 encontrar-se já em «standby», ou seja, quando o contacto «Ready» estiver ligado à ficha X10 (o LED verde está aceso)



ATENÇÃO

7.2

1. Enquanto for aplicado apenas 1 eixo, recomenda-se definir o parâmetro P0030 como «SÍNCRONO». Neste caso, as entradas/saídas de 16 bytes são menos utilizadas do que quando são usados eixos «ASSÍNCRONOS».

(ver também descrição dos parâmetros da máquina)

2. Durante o funcionamento assíncrono com Interface ampliado, têm que ser geralmente transferidos dados standard de 40 bytes, mesmo quando apenas são aceites 1 ou 2 eixos.

Instruções de segurança nos componentes de comando

Nos próprios componentes de comando podem estar afixados os avisos ou as instruções seguidamente descritos para chamar à atenção para determinados pontos.



Aviso referente a uma tensão eléctrica perigosa!



Aviso referente a perigos relacionados com baterias!



Módulos em perigo electrostático!



Antes de abrir tirar o cabo alimentador da rede!



Borne apenas para ligação do condutor de protecção à massa PE!



Só para ligação de um condutor blindado!

**A.1.9 Suomi****Tämän käyttöohjeen turvallisuusohjeet**

Näitä symboleja käytetään tässä käyttöohjeessa seuraavasti.

**VAROITUS**

Tätä symbolia käytetään, kun varoitetaan **vaarallisesta sähköjännitteestä**. Seurauksena voi olla **henkilövahinko**, jos ohjetta ei seurata tai sitä ei seurata tarkkaan.

**VAROITUS**

Tätä symbolia käytetään, jos ohjeiden noudattamatta jättäminen voi johtaa **henkilövahinkoihin**.

**HUOMIO**

Tätä symbolia käytetään, jos ohjeiden noudattamatta jättäminen tai niiden epätarkka seuraaminen voi johtaa **laitteiden tai tiedostojen vahingoittumiseen**.



Tätä symbolia käytetään, kun halutaan kiinnittää lukijan huomio johonkin erikoisseikkaan.

**VAROITUS**

0.1

Henkilö- ja tavaravahinkovaara!

Testaa jokainen uusi ohjelma, ennen laitteiston käyttöönottoa!

**HUOMIO**

0.2

Rakennesaryhmä voi vioittua!

Älä liitä tai irrota rakennesaryhmää ohjauksen ollessa päällekytkettynä! Rakennesaryhmä voi tuhoutua. Kytke ensin ohjauksen verkko-osarakenneryhmä, ulkoinen jännitteentulo ja signaalijännite pois päältä tai irrota ne ja liitä tai irrota rakennesaryhmä vasta sitten!

**HUOMIO**

0.3

Rakennesaryhmä voi vioittua!

Rakennesaryhmän kanssa toimittaessa on kaikkia ESD-suojaan liittyviä toimenpiteitä noudatettava! Elektrostaattista latausta on vältettävä!

**HUOMIO**

2.1

Ympäristöilman keskivertolämpötila ei saa ylittää 24 tunnin aikana 50C!

**HUOMIO**

2.2

Ympäröivä ilma ei saa sisältää suuria määriä pölyä, happeja, lipeitä, syövyttäviä aineita, suoloja, metallihöyryjä tai muita sähköä johtavia epäpuhtauksia. Kostuminen ei ole luvallista.

**HUOMIO**

2.3

Laitteen välittömässä läheisyydessä ei saa olla voimakkaita elektromagneettisia kenttiä.



HUOMIO

3.1

Jotta käyttökenttä voidaan vetää irti käytön aikana, täytyy sovitushajauksesta silloittaa HÄTÄ–SEIS, jotta koneen toiminto HÄTÄ–SEIS voidaan ehkäistä.



VAROITUS

4.1

Verkkohuoltojohtoja asennettaessa on otettava huomioon asiaankuuluvat normit ja ohjeet. Huomioon on otettava etenkin VDE–määräykset (esim. VDE 0100 ja VDE 0113) sekä paikallisen sähkölaitoksen määräykset!

Kaikki liitäntäjohdot on asennettava kuten lohkokytkentäkaavioissa on näytetty!

Sähköliitännän saa suorittaa ainoastaan asiantuntija. Asennettaessa on käytettävä sopivia sähkötyökaluja. Käytettävien muuntajien tulee olla VDE 0551 mukaisia!



HUOMIO

4.2

Verkkojännitteellä käytettävillä laitteilla on tarkistettava ennen käyttöönottoa, vastaako säädetty/vaadittu verkkojännitealue paikallista verkkojännitettä. Verkkojännitteen vaihtelut tai poikkeamat eivät saa ylittää tai alittaa ilmoitettuja toleranssirajoja. Muussa tapauksessa ei voida taata sitä, että toimintakatkoksilta ja/tai vaaratiloilta sähkörakenneryhmissä vältytään.



HUOMIO

4.3

Laitteiston suojajohdinjärjestelmä (maadoitusliitännät) täytyy asentaa verkon muotoisena!

Moduulikotelot, kytkentäkaappikotelot, kytkentäkaapin asennuslevyt jne. on liitettävä suojajohdinjärjestelmään. Suojajohdinjohdotuksella on otettava etenkin huomioon riittävät johdinläpimitat!

Kaikkien laitteiston osien potentiaalintasausjohdot / PE–johdot (etenkin NC:n ja käyttöjen väliset) on pidettävä mahdollisimman lyhyinä ja siten pieniohmisina. Pääsuojajohdinliitännän ja kaikkien sähkövarustuksen osien sekä koneenvälinen vaste ei saa ylittää 0.1 W (katso EN 60204 osa 1)!

Kaikkien suojausten tulee olla – sillä edellytyksellä, että laitteiston osat on maadoituksen puolesta asennettu verkkomaisesti – molemmin puolin asennettu

Käyttöohjearvojohtojen suojajohtimelle täytyy niiden liitäntä ottaa yksittäisten käyttöjen liitäntäolosuhteista, sillä sinne on toisinaan määrätty yksipuolinen liitäntä.



HUOMIO

4.4

– Häiriönpoisto mahdollisimman lähellä häiriölähdettä.

– Johdinvirrat on rajattava turvallisuusmääräysten (kosketussuoja!) mukaisesti.

– Häiriönpoistosuodattimet on tuettava mekaanisesti hyvin, jotta tarinasta johtuvalta murtumalta vältyttäisiin.

– On käytettävä ainoastaan häiriönpoistovälineinä merkittyjä rakennosia



HUOMIO

5.1

CC10:n lähtövaiheet ovat kesto–oikosulkulujia. Jos kuitenkin useat lähdöt ovat oikosulussa, voi seurauksena olla lähtötoimitusvahvistimen tuhoutuminen kohonneen häviötehon takia.

**HUOMIO****5.2**

Jos READY2–kosketus avautuu, ohjearvolähdöt asetetaan heti OV:lle (analogia–GND).

Tämä taso taataan korkeintaan 1 sek! Sen vuoksi käytöt on kytkettävä pois päältä sekunnin kuluessa!

**HUOMIO****5.3**

Servovahvistimia GND–tartutetulla tulolla ei saa liittää CC10:een.

**HUOMIO****5.4**

Kun suoraliitäntään käytetään EXE:ä tai Uas–signaalianturia, on Uas–signaalin oikea johdotus CC10:een tarkistettava!

Avoimet Uas–tulot asetetaan sisäisillä Pull–Up–vastuksilla High–Potentiaaliin (ei jäljellä olevaa mittasysteemivirhettä).

**HUOMIO****7.1**

Ohjauksen päällekytkennän jälkeen tai CC 10–alustusvaiheen aikana ei Interface–signaalien tiloja vielä ole määritetty. Interface–signaaleilla on määritetyt tilat vasta, kun CC 10 on ”käyttövalmis”, s.o. kosketus ”Ready” pistokkeella X10 on suljettu (vihreä LED–merkkivalo palaa).

**HUOMIO****7.2**

Jos ainoastaan yksi akseli on käytössä, on suositeltavaa määrittää parametri P0030 asentoon ”SYNCHRON”. Tässä tapauksessa tarvitaan vähemmän 16 bitin tuloja/lähtöjä kuin ”ASYNCHRON”–akseleilla:

(Katso mylöskin koneparametrien kuvaus)

2. Asynchron–käytöllä laajennetulla Interface:illa on yleensä siirrettävä 40 bitin standardi–interface–tiedot, myöskin kun vain 1 tai 2 akselia on käytössä.

Ohjauskomponenttien turvallisuusohjeet

Ohjauskomponentteihin voi olla merkittynä seuraavat varoitukset ja ohjeet, joiden tarkoitus on kiinnittää käyttäjän huomio tiettyihin seikkoihin:



Varoitus, vaarallinen sähköjännite!



Varoitus, akkujen aiheuttamat vaarat!



Sähköstaattisesti vaarannetut rakenneosat!



Vedä verkkopistoke irti pistorasiasta ennen avaamista!



Pultti vain suojajohtimen PE liitännälle!



Vain suojajohtimen litäntää varten!

A.1.10 Svenska

Säkerhetsanvisningar i denna driftsinstruktion



Dessa symboler används i denna driftsinstruktion för följande förutsättningar.



VARNING

Denna symbol används, vid varning för **farlig elektrisk spänning**. Om denna anvisning inte exakt följs eller inte följs alls kan det medföra **personskador**.



VARNING

Denna symbol används, när **personer kan skadas** om anvisningar inte exakt följs eller inte följs alls.



OBSERVERA

Denna symbol används, när **apparater eller filer kan skadas** om anvisningar inte exakt följs eller inte följs alls.



Denna symbol används, när Ni skall göras uppmärksam på något särskilt.



VARNING

0.1

Fara för person- och sakskador!

Prova varje nytt program innan Ni tar en anläggning i drift!



OBSERVERA

0.2

Fara för en komponentgrupp!

Stick inte in och drag inte heller ur en komponentgrupp när styrningen är tillkopplad! Komponentgruppen kan förstöras. Frånkoppla eller drag först ur styrningens nätdelskomponentgrupp, extern spänningsförsörjning och signalspänningen och stick in eller drag först därefter ut komponentgruppen!



OBSERVERA

0.3

Fara för en komponentgrupp!

Vid arbeten med komponentgruppen skall alla åtgärder för ESD-skydd innehållas! Statiska urladdningar skall undvikas!



OBSERVERA

2.1

Omgivningens genomsnittliga temperatur får under ett dygn inte överstiga 50 °C.



OBSERVERA

2.2

Omgivningsluften skall vara fri från högre koncentrationer av damm, syror, lutlösningar, korrosionsmedel, salter, metallångor och andra föroreningar som leder elektricitet. Daggbildning får inte förekomma.



OBSERVERA

2.3

Inga starka elektromagnetiska fält får uppstå i närheten av apparaterna.

**OBSERVERA****3.1**

För att kunna dra ut manöverfältet under körning, måste NÖD-FRÅN-knappen överbryggas i anpassningsstyrningen, så att funktionen NÖD-FRÅN undertrycks på maskinen.

**VARNING****4.1**

Vid anslutning för el-försörjningen skall de tillämpliga normerna och bestämmelserna följas. Särskilt skall VDE-bestämmelserna (t. ex. VDE 0100 och VDE 0113) och bestämmelserna från det lokala el-verket beaktas!

Alla anslutningskablar skall föras enligt illustrationen i blockschemat!

Den elektriska anslutningen får endast genomföras av behörig personal. Därvid skall lämpligt elverktyg användas. Principiellt skall transformatorer enligt VDE 0551 användas!

**OBSERVERA****4.2**

Vid apparater, som drivs med nätspänning, skall före idrifttagandet kontrolleras om det inställda/erforderliga nätspänningsområdet överensstämmer med den lokala nätspänningen. Variationer eller avvikelser hos nätspänningen från det nominella värdet får inte över- eller underskrida angivna toleransgränser. I annat fall kan funktionsavbrott och/eller faror för de elektriska komponentgrupperna inte uteslutas.

**OBSERVERA****4.3**

Anläggningens skyddsledarsystem (jordade anslutningar) skall byggas upp nätformigt! Modulhuset, manöverskåpeshuset, montageplattorna i manöverskåpet osv skall anslutas till skyddsledarsystemet. Beakta vid koppling av skyddsledarna att ledarean är tillräcklig!

Alla anläggningsdelars potentialutjämningsledningarna / PE-ledningar (särskilt mellan NC och drivningar) skall vara så korta som möjligt och därmed lågresistiva. Motståndet mellan anslutningen för huvudledaren och den elektriska anslutningens alla delar samt maskinen får inte överstiga 0,1 W (se EN 60204 del 1)!

Alla avskärmningar skall – under förutsättning, att anläggningsdelarnas jordning är elektriskt uppbyggd – anordnas på båda sidor.

För avskärmningsledningarna för drivningens börvärdesledare skall anslutningen hämtas från de enstaka drivningarnas anslutningsbestämmelser, då ensidig anslutning ibland är föreskriven.

**OBSERVERA****4.4**

- Avstörning så nära störningskällan som möjligt –
- Begränsa urladdningsströmmen enligt säkerhetsbestämmelserna (beröringsskydd!).
- Avstörningsled skall stödjas mekaniskt bra, för att undvika brott genom vibrationer.
- Använd endast komponenter, märkta för avstörning

**OBSERVERA****5.1**

Utgångsstegen hos CC10 tål kortslutning. Om flera utgångar har kortslutits, kan den förhöjda effektförlusten medföra förstöring av utgångsoperationsförstärkaren.

**OBSERVERA**

5.2

Om READY2-kontaken öppnar, sätts utgångarna för börvärde omedelbart på 0V (analog ground). Denna nivå garanteras under högst 1 sek! Därför måste drivningarna fränkopplas inom 1 sekund!

**OBSERVERA**

5.3

Servoförstärkare med ground-behäftad ingång får inte anslutas till CC10.

**OBSERVERA**

5.4

Vid användning av en EXE eller en givare för direktanslutning med signal Uas skall kontrolleras att signalen Uas är riktigt ansluten till CC10! Öppna Uas-ingångar ansluts genom interna Pull-Up-motstånd till High-Potential (inget mätsystemfel finns).

**OBSERVERA**

7.1

Efter tillkoppling av styrningen resp. under CC10:s initialiseringsfas är gränssnittsignalernas tillstånd ännu inte definierade. Gränssnittsignalerna får först definierade tillstånd när CC10 är "startklar", dvs kontakten "ready" på stift X10 är sluten (grön LED lyser).

**OBSERVERA**

7.2

1. Om endast axel 1 är applicerad, rekommenderas, att definiera parameter P0030 till "SYNKRON". I detta fall erfordras 16 byte ingångar/utgångar färre än vid "ASYNKORN"-axlar.

(se även maskinparameter-beskrivningen)

2. Vid asynkron-drift med utvidgat gränssnitt skall generellt 40 byte standardgränssnittdata överföras, även om endast 1 eller 2 axlar är applicerade.

Säkerhetsanvisningar på styrningskomponenterna

På styrningskomponenterna kan följande varningar och anvisningar vara placerade, som vill göra Er uppmärksam på vissa saker:



Varning för farlig elektrisk spänning!



Varning för faror genom batterier!



Komponenter som kan skadas av elektrostatisk urladdning!



Drag ur kontakten innan öppning!



Bultar endast för anslutning av skyddsledaren PE!



Endast för anslutning av en avskärningsledare!!

Bosch-Automationstechnik

Robert Bosch GmbH
Geschäftsbereich
Automationstechnik
Industriehydraulik
Postfach 30 02 40
D-70442 Stuttgart
Telefax (07 11) 8 11-18 57

Robert Bosch GmbH
Geschäftsbereich
Automationstechnik
Fahrzeughydraulik
Postfach 30 02 40
D-70442 Stuttgart
Telefax (07 11) 8 11-17 98

Robert Bosch GmbH
Geschäftsbereich
Automationstechnik
Pneumatik
Postfach 30 02 40
D-70442 Stuttgart
Telefax (07 11) 8 11-89 17

Robert Bosch GmbH
Geschäftsbereich
Automationstechnik
Montagetchnik
Postfach 30 02 07
D-70442 Stuttgart
Telefax (07 11) 8 11-77 12

Robert Bosch GmbH
Geschäftsbereich
Automationstechnik
Antriebs- und Steuerungstechnik
Postfach 11 62
D-64701 Erbach
Telefax (0 60 62) 78-4 28

Robert Bosch GmbH
Geschäftsbereich
Automationstechnik
Schraub- und Einpreßsysteme
Postfach 11 61
D-71534 Murrhardt
Telefax (0 71 92) 22-1 81

Robert Bosch GmbH
Geschäftsbereich
Automationstechnik
Entgrattechnik
Postfach 30 02 07
D-70442 Stuttgart
Telefax (07 11) 8 11-34 75

Technische Änderungen vorbehalten

Ihr Ansprechpartner

BOSCH



Robert Bosch GmbH
Geschäftsbereich
Automationstechnik
Antriebs- und Steuerungstechnik
Postfach 11 62
D-64701 Erbach
Telefax (0 60 62) 78-4 28